

Bottle Rocket Handbook

Leo C. Singleton IV

Copyright © 2001 Leo C. Singleton IV. All rights reserved.

No part of this book may be reproduced or transmitted in any form or by any means, without the prior written permission of the author.

Acknowledgments

Although I can take credit for being the author of this handbook, much of its content is the hard work of other members, past and present, of the Columbus High School Science Olympiad team. I would like to take this opportunity to thank them and the many others for their contributions to this handbook.

Will Evans, the only one among us who actually plans to become an aeronautical engineer, is responsible for many of the building techniques listed in the handbook. He protected his designs for reinforced fins, airspeed flaps, and drogue chutes as if they were children, before I decided to publish them to the world. Thanks Will.

Jamal Shaukat, our longest member of the Science Olympiad team. Two years ago, he and I spent many long hours developing the elliptical parachute algorithms and building the first parachutes. And now, despite being a sophomore in college, Jamal still manages to attend more state competitions and rocket launches than anyone else on the team.

Linda Owens, our Science Olympiad coach, whom I promised to leave plans and drawings for my rockets before I graduate. Instead I'm leaving her a book. Good enough.

And the rest of the **Columbus High School Science Olympiad Team**, especially those of you who have come out to support us on cold, rainy days, chasing rockets through an overgrown field of weeds and thornbushes. We couldn't have done it without you.

Contents

Introduction	1
Format	3
I Rocket Theory	5
1 Ten Common Myths	7
2 Five Critical Factors	11
2.1 Reliability	11
2.2 Rigidity	12
2.3 Precision	12
2.4 Weight	13
2.5 Drag	13
3 Forces	15
3.1 Liftoff	15
3.2 Launch	17
3.3 Air Pulse	18
3.4 Glide	19
3.5 Descent	20
4 Stability	21
4.1 What is Stability?	21
4.2 Swing Test	22

4.3	Center of Gravity and Center of Pressure	22
4.4	Cross-Section Method	25
4.5	Barrowman Equations	27
4.6	Stability Tips	27
4.6.1	Bottle Shape Affects Stability	27
4.6.2	Semi-Stable Rockets	28
5	Simulator Data	29
5.1	Typical Launch	30
5.1.1	Height	31
5.1.2	Velocity	32
5.1.3	Acceleration	33
5.2	Water Volume	34
5.3	Mass	34
II	Rocket Construction	39
6	Fins	41
6.1	Single-Ply Fins	42
6.1.1	Fin Patterns	42
6.1.2	Constructing	42
6.1.3	Breaking Point	43
6.2	Reinforced Balsa Fins	44
6.3	Other Materials	45
6.4	Attaching Fins to Rockets	45
6.5	Extra Reinforcement	46
7	Parachutes	47
7.1	Dome Parachutes	47
7.2	Elliptical Parachutes	49
7.3	Constructing a Panel	49
7.4	Methods of Construction	53
7.4.1	Glue or Tape	53
7.4.2	Iron	53
7.4.3	Soldering Iron or Woodburner	54

7.5	Shroud Lines	55
8	Parachute Deployment Systems	57
8.1	Gravity Deployment	57
8.2	Airspeed Flap Deployment System	58
8.2.1	Platform	60
8.2.2	Nosecone	61
8.2.3	Main Airspeed Flap	61
8.2.4	Trigger Flap	63
8.2.5	Tensioning the Rubber Bands	64
8.3	Airspeed Flap With Drogue	64
9	More Parachute Tips	67
9.1	Packing Parachutes	67
9.2	Testing Parachutes	67
9.3	Multiple Parachutes	68
9.4	Parachute Age	68
9.5	Shroud Tangling	69
10	Nosecones	71
10.1	Materials	71
10.2	Aerodynamics	72
III	Mathematical Calculations	73
11	Dome Parachute Calculations	75
12	Elliptical Parachute Algorithms	79
12.1	Tangent Points Algorithm	80
12.2	Angle Repetition Algorithm	88
13	Simulators	89
13.1	Notation	90
13.2	Constants, Variables, and Functions	91
13.3	Acceleration, Velocity, and Height	91
13.4	Computer Integration	92

13.5	Calculations	94
13.5.1	Launch Rod	94
13.5.2	Pressurized Bottle, Water, and Air	96
13.5.3	Preliminary Propulsive Calculations	97
13.5.4	Mass	98
13.5.5	Air and Atmosphere	98
13.5.6	Parachute	101
13.6	Forces	102
13.6.1	Gravity	102
13.6.2	Launch Rod Reaction Force	102
13.6.3	Wind Resistance	103
13.6.4	Propulsive Forces	103
13.6.5	Air Pulse	108
13.6.6	Parachute Drag	108
13.7	Conclusion	109
A	Water Markings	111
B	Stability Markings	113
C	Rocket Material Weights	115
C.1	Bottles	115
C.2	Balsa Wood	117
C.3	Tape	117
C.4	String	117
C.5	Other Materials	118
D	Parachute Materials Chart	119
E	Further Reading	121

Introduction

Rocket science doesn't require white lab coats or a job in Cape Canaveral. You don't need a million-dollar budget or a Ph.D. either. An empty soda bottle and an air pump will do just fine, because rocket science is *the theory* behind launching these rockets into the air, no matter whether you are launching a state-of-the-art rocket or an empty soda bottle.

Although pressurized air and water is not quite the same as liquid hydrogen, we still calculate it using the same laws of physics. And it's not as complex as you may think. Typical high school math and physics classes cover 95% of the information needed to understand rocket theory, but few of them take the extra step to apply the basic principles to more complex applications such as rockets.

Science Olympiad offers students the opportunity to explore rocketry and to extend their classroom knowledge to practical applications. This handbook is intended to be a guide to the Science Olympiad event, but it can also provide a useful resource for all types of hobby rockets.

While reading this book, every student (and teacher) has one question in mind: How do I get the longest time aloft? There is no single formula or design to guarantee one- and two-minute launches; the key to making a rocket stay aloft for a minute is to understand *why* the rocket stays aloft for a minute.

Although this handbook contains the "secrets" of building a one-minute rocket, you will not find plans or instructions for

building a winning rocket. However, you will find what I call “building techniques”—these are methods that I and other students at Columbus High have developed. Plans would restrict creativity and ingenuity, and defeat the purpose of the Bottle Rocket event. Techniques, on the other hand, have the opposite effect. By understanding *how* to construct a fin capable of withstanding strong forces and *how* to build a parachute by melting plastic bags will allow you to create any fin or parachute that you can imagine.

Format

This is a handbook—a guide containing lots of various topics related to water rockets. It is not a typical book which you would read cover-to-cover. In fact, the chapters in this book could probably be arranged in any random order, and it would make little difference.

The chapters are definately not arranged in order of difficulty. Do not be discouraged if a chapter seems too long or overly technical. Skip over it and go on to another chapter.

To make the book more organized, the chapters are grouped into three main categories: theory, construction, and mathematics.

The first part, *Rocket Theory*, is the most general and explores the fundamentals of rocketry. Fundamentals often carries a connotation of “basics,” but this is not the case in this handbook. By “fundamentals,” I am referring to the physics principles which govern rockets and how to apply these principles to building a good rocket. The fundamentals in this book cover topics such as stability and forces, which are overlooked by most other books. These fundamentals are the key to developing a winning design, because they eliminate the guesswork that would otherwise be required. Once you understand the fundamentals, you will be able to look at your rocket, and spot areas for improvement, without using trial-and-error techniques.

Part two, *Rocket Construction*, consists of chapters that each focus on one particular component of the rocket. The building techniques contained in this handbook are ones that we at

Columbus High School have tested and used, but they are not the only (and likely not the best) methods for building rockets. Always feel free to try new methods and materials.

The third part, *Mathematical Calculations*, is really a supplement to the first two parts. Earlier chapters will refer to parachute designs and simulator results obtained from the formulas and algorithms in Part III. Although it is not necessary to understand these formulas to use the data, they provide the information needed to develop computer models and simulations.

Part I

Rocket Theory

Chapter 1

Ten Common Myths

Myths about rocket design are everywhere. This chapter should help to clear up 10 of the most common misconceptions about the design of water rockets.

Myth #10 – If it looks good, it will fly.

Few students understand the physics principles which determine a rocket's flight. Understanding these principles—forces (thrust, gravity, etc...), drag, and stability—are critical to building a successful rocket. Often, the “this looks about right” method does not work, because large, supersonic rockets are designed differently, because of their high speeds and computer guidance systems. An introduction to rocket design begins in chapter 3.

Myth #9 – Using a heavy nosecone is the most reliable way to deploy a parachute.

There are many better ways to deploy a parachute using an “active” system—one involving spring-loading or rubber bands. Using an airspeed-sensitive flap, these can be set to deploy at apogee, utilizing the maximum height of the rocket, and approaching an 80–95% reliability rate (depending on how well the system is constructed and tested). See chapter 10 for more on active deployment systems.

Myth #8 – Duct tape is the best material for attaching rocket parts, because it is strong.

Duct tape is stronger than necessary for most rocket parts. It adds unnecessary weight to the rocket, which greatly decreases the rocket's performance. (A typical piece of duct tape weighs 3 to 10 grams, decreasing a rocket's time aloft by 1 to 3 seconds for *every piece* of tape used. See chapter 3 for more on the effect of excess weight on rockets.) Packaging tape or mailing tape is a much lighter alternative, and offers sufficient strength.

Myth #7 – All materials on water-powered rocket must be waterproof.

Waterproof materials are not necessary on any part of the rocket, even fins. It is more important to use light materials, instead of waterproof materials. A *stable* rocket will always fly vertically, so that the water inside will be propelled away from the rocket. (Learn how to make a rocket stable in chapter 5.) Of course, use a funnel, and be careful when filling, especially if you use balsa or cardboard on your rocket.

Myth #6 – If the rocket holds together on the ground, it will be strong enough during flight.

A typical rocket experiences 30 to 40 G's of acceleration during launch. This means that during a fraction of a second of the flight, pieces of the rocket has the effective weight of 30 to 40 times their normal weight. For example, a 30 gram parachute will weigh as if it were 900 to 1200 grams! If the platform that supports the parachute is not strong enough to support this much weight, it will likely break during launch. See chapters 13 and 14 to learn more about calculating a rocket's acceleration using computer simulations.

Myth #5 – The amount of water in a rocket has little effect, as long as it is around 50%.

This is false for two reasons:

1. The amount of water has a *great* effect on the rocket's height. In bottle rockets, water is thrust, but it also adds

excess weight. You must reach a compromise between thrust and weight to find the optimum water level.

2. 50% is too much water for a typical rocket. The optimum water level varies for each rocket, depending on weight and drag, but it is typically between 40% and 45% of the bottle's actual volume. (To learn how to calculate the optimum water level using a simulator, see chapters 13 and 14.)

Myth #4 – Adding fins, no matter what type or where they are placed, will improve a rocket's height.

Height is a result of many factors—most importantly, stability. Fins will improve stability *only* under two conditions:

1. The fins must be rigid. They must be able to “push” against the wind, even when the rocket is travelling at speeds over 80 MPH.
2. The fins must be located *behind* the center of gravity of the rocket. Otherwise, they will have the opposite effect, making the rocket *less* stable and *decreasing* the height.

See chapter 5 to learn how to determine the effectiveness of fins.

Myth #3 – Aluminum duct tape is good for attaching fins.

Aluminum duct tape does not work for attaching fins. See myth #4 above—fins must be rigid. If they can be bent back and forth, they are not doing much good. For other parts, aluminum tape is usually a waste of weight. Aluminum tape should only be used *sparingly*, and only on *moveable* parts.

Myth #2 – Bigger parachutes are better.

Yes, bigger parachutes result in a longer time aloft, but bigger parachutes cause extra problems: they are less reliable, they deploy slower, and they are more likely to fly into trees. A large parachute is not necessary for a flight in excess of one minute—a

medium-sided parachute works fine (80 to 120 cm in diameter), and it is much more reliable. Weight is more important factor—you will have much more success if you use a light rocket with a medium-sized parachute.

Myth #1 – Adding weight to the rocket’s nosecone will increase the rocket’s time aloft.

Adding weight to a rocket’s nosecone improves stability, which may improve the rocket’s height. But this weight is only beneficial during the first four seconds of the launch. After apogee, as the parachute opens and the rocket descends, the extra weight causes the rocket to fall faster, decreasing the time aloft. There is a way to have the same increase in height, without adding weight: properly placed fins. See chapter 5 to learn more.

Chapter 2

Five Critical Factors

A good rocket design can be summarized in five words: reliability, rigidity, precision, weight, and drag. There is no perfect rocket, but the following five critical factors will ensure that your design is as successful as possible. The factors are listed in their order of importance. For example, do not add weight (#4) to a rocket to decrease drag (#5), and do not select a material that is weighs less (#4), unless it is strong (#2).

2.1 Reliability

Especially in the Science Olympiad competition, where rockets are scored based on time aloft, reliability is critical. To consistently score well, you must have a rocket which reaches its maximum height, and has a parachute that reliably deploys. Remember, a rocket that consistently gets 20 seconds aloft will on average, score higher than a rocket which reaches one minute, but only works 20% of the time.

Simple designs are not necessarily the most reliable. A semi-complex design, such as an airspeed-deployment system, tends to be significantly more reliable than a rocket which relies on gravity, but *only if it is thoroughly tested*. Testing is the key to reliability. A reliable rocket is the result of thorough testing,

both on the ground, before it is actually launched, and in the air, through numerous launches.

2.2 Rigidity

Rigidity is the most commonly overlooked factor of rocket design, but it is one of the most critical. The simulators described in later chapters will take the shape of the rocket and fins into consideration. If the rocket or any part of the fins is able to flex, there is no way to accurately calculate how it will perform in the air.

Obviously the rocket cannot be perfectly rigid, since we are building it out of light materials such as plastic and balsa wood, but you should always make a reasonable attempt at rigidity. A good test of rigidity is simply by handling your rocket. You should be able to pick up your rocket by *any* part (fins and nosecone included), handle it, shake it around, etc. . . and *nothing* on the rocket should ever move. If it bends when you handle it, it will definitely bend under the 80 MPH of wind from the launch.

2.3 Precision

When working on a such a small scale like water rockets, precision is essential. On deployment systems like the airspeed-flap, one millimeter of adjustment can make the difference between a rocket that is 90% reliable and one that is only 10% or 20%. Precision is also needed for the simulators—one centimeter will make the difference between a stable and an unstable rocket.

Like rigidity, we must be realistic when measuring precision, due to the materials we have to work with. If you take your time when constructing pieces, and do it carefully with a sharp knife, no part of the final rocket should vary by more than 2 or 3 millimeters from your plans.

2.4 Weight

Weight is a misunderstood factor of rocket design. When used in reasonable amounts (80 to 200 grams), rocket weight only has a small effect on the rocket's maximum height. Stability is far more important.

Although the weight of a rocket does not significantly affect its height, it has a great affect on its time aloft. As the parachute on a rocket inflates, the rocket quickly slows down, until it reaches its terminal velocity (which usually takes about 2 to 3 seconds). Once the rocket has slowed to its terminal velocity, it continues to fall at this constant speed until it hits the ground. This is where weight comes in—terminal velocity depends on weight and parachute area—the more the rocket weighs, the greater its terminal velocity, and the faster it will fall. As a general rule of thumb, if you reduce the weight of your rocket by 3 grams, you will increase its time aloft by 1 second.

2.5 Drag

Drag is the factor which primarily determines a rocket's height. It is important to design a rocket with low drag to reach its maximum height, because the higher a rocket is when the parachute deploys, the longer it will stay aloft. Drag, however, is not as important of a factor as weight—drag only affects the first four seconds of the launch (from liftoff to apogee). Weight affects the rocket for the rest of the flight, from apogee, until it touches the ground.

Chapter 3

Forces

So what makes a rocket fly? Of course, it is the pressurized air inside the rocket that propels it upwards, but why does adding water increase the height of the rocket? And how does the size of the nozzle affect the rocket? To answer these questions, we must look at the forces which affect the rocket during its flight.

This chapter provides a brief overview of the forces involved with water rockets. In this chapter, we will only look at the forces, not the actual formulas for calculating them. To learn how to actually calculate these forces, see chapter 13, *Simulators*.

3.1 Liftoff

When the rocket is sitting on the launch pad, the nozzle of the rocket typically fits over some type of rubber or metal stopper, called a “launch rod.” For the first few tenths of a second, all of the rocket’s propulsive forces are generated by the pressurized air pushing against the launch rod. This pushes the rocket upwards, until the rocket lifts off the launch pad. We call this the “launch rod reaction force.”

While the launch rod reaction force may seem insignificant (it only occurs for a fraction of a second), it becomes extremely important when working with a simulator. As a simulator will

show you, the rocket typically reaches a speed of over 10 MPH before it ever leaves the launch pad.

The next force to consider is gravity—the force which pulls the rocket towards the ground. If the launch rod reaction force is not greater than the force of gravity, the rocket will not lift off the ground.

The force of gravity is proportional to the rocket's total mass. At this point, the force of gravity is constant, since the mass is not changing, but in the next stage, this force will be constantly decreasing as water is expelled through the nozzle.

There is one last force to consider—drag. As the speed of the rocket increases, there is a friction with the air, creating a force in the opposite direction of the rocket's movement.

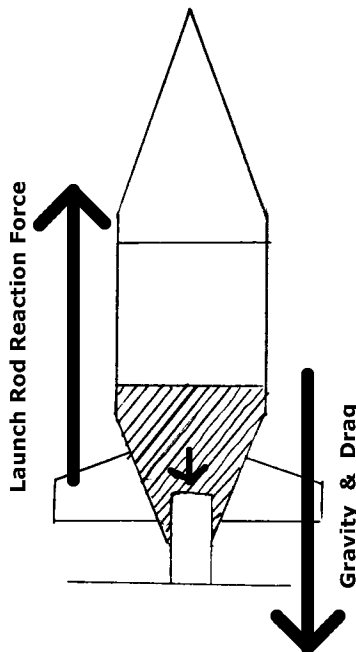

Figure 3.1: Forces at Liftoff

3.2 Launch

Our rocket has cleared the launch pad. We no longer have a launch rod reaction force, but our propulsion now comes from the water inside the bottle. The pressurized air pushes against the surface of the water, causing the water to be expelled through the nozzle of the bottle. This creates a propulsive force, pushing the rocket upward.

Newton's third law of motion states: "For every action there is an equal, but opposite, reaction." In this case, our action is the expulsion of the water out of the nozzle, and our reaction is the propulsive force on the rocket generated by our action.

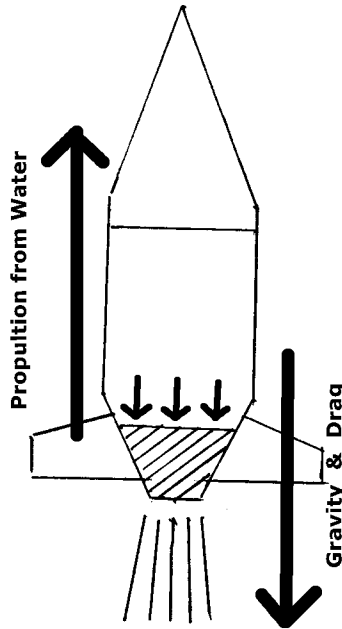

Figure 3.2: Forces during Launch

3.3 Air Pulse

After all of the water has been propelled out of the rocket, the “air pulse” occurs. The air pulse is caused by the remaining air pressure in the bottle leaving through the nozzle, much like the water did earlier. This force is not nearly as great as the one generated by the water, but it is important to consider it.

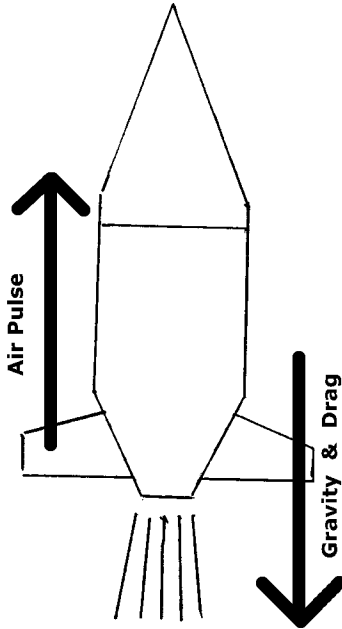

Figure 3.3: Forces during Air Pulse

3.4 Glide

From this point on, our rocket no longer has any propulsive forces. Since it already has so much speed built up, it continues travelling upward, until the forces of drag and gravity finally bring the rocket to a stop. The point at which the rocket's velocity is zero is called "apogee."

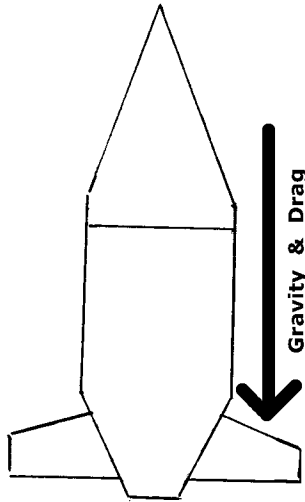

Figure 3.4: Forces during Glide

3.5 Descent

After apogee, the rocket begins to descend. The force of gravity is the same, but one important change has occurred—drag is now an upward force, since drag is always in the opposite direction of the path of the rocket. In addition, we must now consider the drag created by not only the rocket, but also the parachute. From this point on, drag is the force that prevents the rocket from gaining too much speed as it descends. Otherwise, the force of gravity would pull the rocket to the ground in a matter of seconds.

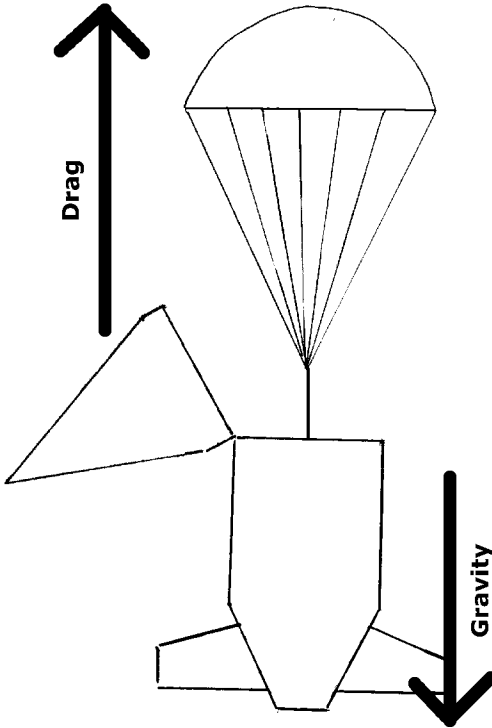

Figure 3.5: Forces during Descent

Chapter 4

Stability

Stability is the single most important factor in rocket design, and it is also the most commonly overlooked. A stable rocket not only goes much higher than one that is only moderately stable, but it also has a much smoother flight, reducing the chance of parachute failures.

One common way to improve the stability is to add weight to the rocket, which does improve the stability (you will understand why later), but a much better way to improve stability is by adding fins. This is not a simple task though. Before adding fins, it is important to understand the factors which contribute to the efficiency of the fins. A rocket with large fins is not necessarily more stable than one with small fins—it depends on the shape and position of the fins, and the shape and weight of the rocket itself. Understanding rocket stability will allow you to make a stable rocket while using the smallest fins, and adding the least amount of excess weight and drag to the rocket.

4.1 What is Stability?

Stability does not necessarily mean to fly in a straight line, or to fly vertically—it is the tendency of a rocket to rotate towards the relative wind. The relative wind is the wind “felt” on the

front of the rocket as it is moving. For example, if the rocket was moving at 50 MPH on a windless day, it would “feel” 50 MPH of wind on the front of the rocket, meaning there is a relative wind of 50 MPH. The relative wind is relative to the movement of the rocket. The relative wind is always in the opposite direction of the rocket.

4.2 Swing Test

One method of determining rocket stability is the swing test. The swing test is done on a ready-to-fly rocket by attaching a string to it on the point where it balances and then swinging it in a large circle (about 10 feet). If the rocket points in the direction that it is swinging, the rocket is probably stable.

The swing test has two major downfalls. First, it can only be done on a ready-to-fly rocket. The only way to test different fin configurations is to actually build the fins and attach them to the rocket. This is not only time-consuming, but can also get expensive—**balsa wood** is not cheap. The second downfall of the swing test is that it is not an accurate simulation of a rocket’s flight. A rocket never actually experiences circular motion as it does in the swing test. Sometimes, a rocket can fail the swing test, but actually be stable when it is launched.

4.3 Center of Gravity and Center of Pressure

Before we look at more advanced methods of calculating stability, we must understand two points and how they contribute to rocket stability: the center of gravity (CG) and the center of pressure (CP).

The center of gravity is the center of the mass of a ready-to-fly rocket. It is the point where the rocket balances, and the point at which it rotates during flight. The center of gravity can either be measured by experimentation (finding the balancing point of the

rocket using string or your finger), or by using force-balancing equations (see any introductory physics textbook).

Just as the center of gravity is the point where the gravitational forces of the rocket balance, there is also a point at which the aerodynamic forces (such as wind resistance) balance. This point is called the center of pressure.

The center of pressure is not nearly as easy to calculate as the center of gravity. Without sophisticated equipment, there is no way to experimentally determine the center of pressure, but there are two mathematical methods to accurately estimate the point: the cross-section method and the Barrowman equations, which will be explained in the next section. The benefit of mathematically calculating the center of pressure, and using force-balancing equations to find the center of gravity, is that we can predict how a rocket will fly from the plans for it, without actually building the rocket. If we find out that the rocket is not stable, we can make changes to the plans before we start building the rocket.

In a stable rocket, the center of pressure must be located aft of the center of gravity. This is because the aerodynamic forces centered at the center of pressure are in the direction of the relative wind (the opposite direction of the rocket). If the rocket is moving up, the aerodynamic forces are pushing down on it.

Now, let's look at how these forces work in flight. The rocket starts off pointing into the relative wind, but eventually, some unpredictable force (uneven drag on the rocket, a small gust of wind, etc.) will cause the rocket to stray from its course. If the center of pressure is located aft of the center of gravity, the aerodynamic forces will work to pull the bottom of the rocket back in line with the relative wind, pointing the rocket back in the direction of the relative wind. This makes a stable rocket. If the center of pressure were forward of the center of gravity, the opposite would happen. The aerodynamic forces would pull the nose in the opposite direction that it should move, causing the rocket to spin out of control—an unstable rocket.

A rocket is not necessarily stable or unstable. There are many

Stable Rocket

CP is located aft of CG

Aerodynamic forces work to right rocket

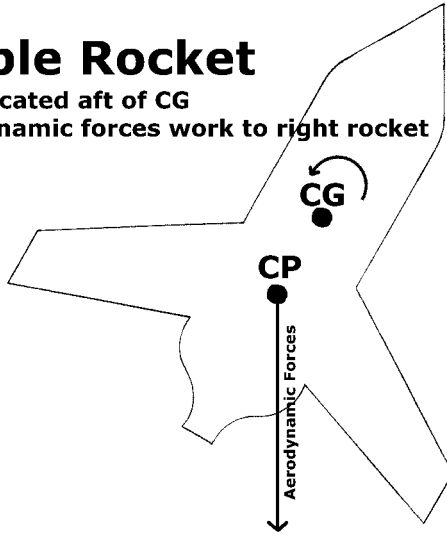

Unstable Rocket

CP is located forward of CG

Aerodynamic forces work against righting

Rocket will spin out of control

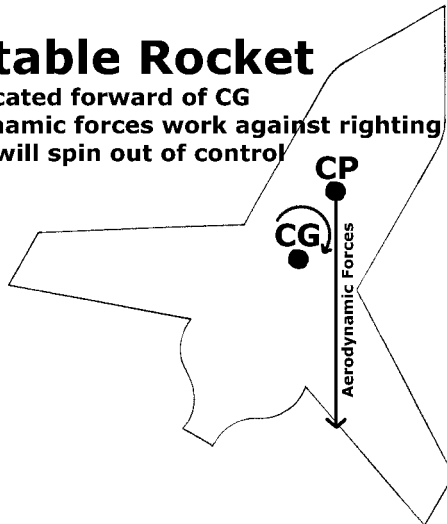

Figure 4.1: The position of the CP in relation to the CG determines stability

different “degrees” of stability—one rocket can be more stable than another. Rocket stability is compared using body calibers. One caliber is equal to the maximum diameter of the rocket (the actual round body, not including fins and other protrusions). The distance between the CP and the CG is referred to as the static stability margin¹. Thus, if the static stability margin is equal to the diameter of the rocket, the rocket has one caliber of stability.

In general, one caliber of stability or greater means the rocket is stable. A negative stability indicates that the rocket is unstable—it will likely spin out of control, and only get about 30 feet of altitude.

There is one other factor to consider—a rocket that is “too stable.” Yes, this is possible. Normal stabilities range from one to three calibers, but too much higher can result in a rocket that is too stable. This can happen when there is a crosswind at the launch site. This crosswind becomes a component in the relative wind, and will cause the rocket to point into the wind, launching off to the side instead of perfectly vertical. The higher the stability of the rocket, the more likely it is to follow the crosswind.

4.4 Cross-Section Method

The simplest method of determining the center of pressure is the cross-section method. If you take a cross-section through the center of your rocket, from the tip of the nosecone, straight down through the nozzle, the center of the surface area of this cross-section will be the center of pressure. You can either find this mathematically, by breaking it up into rectangles, triangles, and other geometric shapes, or you can actually trace your cross-section on a piece of cardboard or other firm material, and find the balancing point of the cardboard. The point where the card-

¹A positive static stability margin indicates that the CP is aft of the CG; a negative means that the CP is forward of the CG

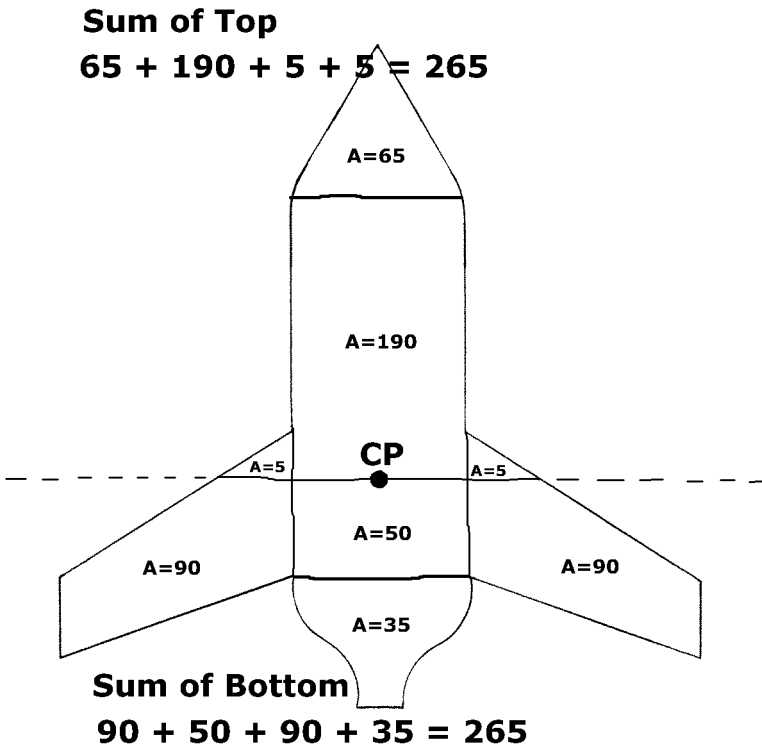

Figure 4.2: The Cross-Section Method finds the center of the surface area of a cross-section of a rocket

board balances (the *center of gravity* of the cardboard) is also the center of its surface area.

There are two main downfalls to this method. First, finding the center of the surface area can be time-consuming. It takes only a few minutes to make the calculations, but it often takes five or ten modifications to a rocket's design before you get the stability just right. A few minutes can quickly turn into a few hours when repeating the calculations over and over again. Second, this method has no way to calculate the effect of different numbers of fins on a rocket. Using the cross-section method, a

rocket with three fins has the same stability as a rocket with four fins, as long as the fins are the same shape and size. Obviously, the one with four fins is more stable, but remember, the cross-section method is only an approximation.

4.5 Barrowman Equations

The most accurate center of pressure calculations come from what are known as the Barrowman Equations. These are a set of equations, developed by aeronautical engineer James Barrowman, which are used to estimate the center of pressure of subsonic rockets. For bottle rockets, which do not even exceed 100 MPH, these equations are more than accurate enough. The best way to use the Barrowman Equations is using a computer simulator, because it will allow you to try different modifications to your rocket to fine-tune its stability. The Barrowman Equations are used commonly by rocket hobbyists, so there is a lot of information about them available on the Internet.

The best calculator for the Barrowman Equations is the *VCP CP/CG Calculator*, available for download as freeware on the Internet. *VCP* allows you to enter your rocket as a series of body sections of varying diameters and masses, add a nosecone and fins, and determine both the center of gravity and center of pressure with a single program. *VCP*'s coordinate system takes a while to familiarize yourself with, but it is well worth the effort.

4.6 Stability Tips

4.6.1 Bottle Shape Affects Stability

One important factor in designing a stable rocket is considering the stability of the bottles used. Different bottles have different natural stabilities. Bottles with a short center-section and a long neck have a naturally high center of gravity. High, that is, if it is used as a rocket; low if the bottle is sitting on a shelf. Many of the

newer bottles are designed this way, because they are less likely to tip over. When we flip the bottle upside-down, to be used as a rocket, this shape works to our benefit, because the center of gravity is already high in the rocket, resulting in smaller fins and less weight that has to be added to make a stable rocket.

4.6.2 Semi-Stable Rockets

One theory in rocket design is to design a rocket that is stable when the nosecone is attached and the parachutes are packed, but with a rocket body that has a negative stability on its own. This can take much fine-tuning in the simulator before it is ever built, but it can be worth the effort when the rocket is actually launched. Semi-stable rockets, such as these, seem to launch normally, like an ordinary stable rocket, but if the parachutes fail during the decent, these rockets descend on their side, due to the body's negative stability, which creates enough drag to drastically slow the rocket down. Not only does this result in a longer time aloft (10 to 15 seconds, versus 6 to 8 with a fully stable rocket), but also causes less damage to the rocket during a crash-landing.

There is one problem with this design: some larger parachutes require the rocket to be falling fast before the parachute will deploy. The parachute may not open until the rocket loses most of its height, or the parachute may not open at all. Problems such as these can sometimes be fixed by using a drogue chute, which will be discussed later.

Chapter 5

Simulator Data

Chapter 13 explains the mathematics in creating a computer simulator for water rockets. Even without understanding how these simulators work, we can still use the results from a typical simulator to learn how to use this data to build an optimum rocket.

Simulators are great tools for designing water rockets, because they allow you to test numerous factors, such as mass, water level, and parachute size, without the hours of launching required to do traditional experimentation.

There are numerous simulators available on the Internet, which work similar to the methods described in chapter 13. See the *Further Reading* section for more information.

5.1 Typical Launch

We will start by looking at the height, velocity, and acceleration of a typical launch. For this demonstration, we will use a 120 gram, 2 liter rocket with a 1 meter diameter parachute, launched with 40% water at a pressure of 60 PSI. We will also assume that it takes 1 second for the parachute to fully deploy.

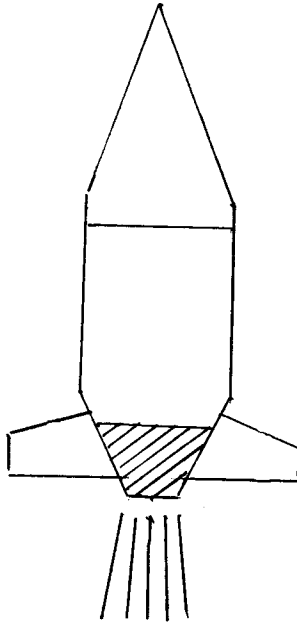

5.1.1 Height

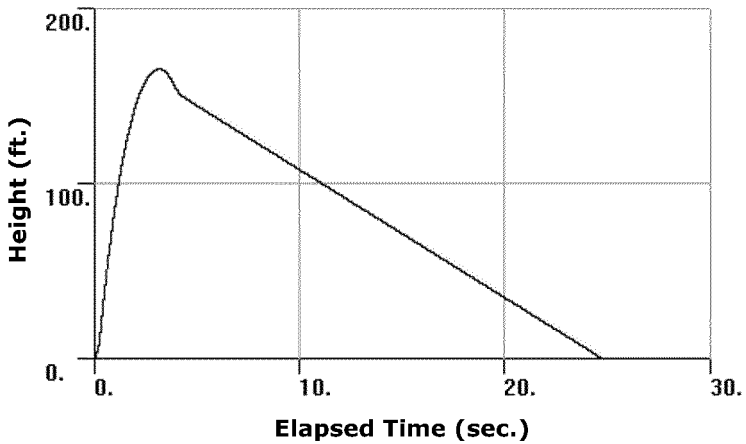

Figure 5.1: Height of the rocket during a typical launch

The height graph provides some interesting data. First and foremost, you should notice that this rocket will stay aloft for 25 seconds (assuming the parachute deploys properly and there is no wind). Next, notice the peak on the left side of the graph—here, the rocket reaches apogee about 3 seconds into the flight, at a height of 170 feet. Afterwards, the rocket begins to pick up speed as the parachute deploys. The rocket loses 15 to 20 feet of altitude before the parachute fully deploys, and the rocket descends at a constant velocity thereafter.

5.1.2 Velocity

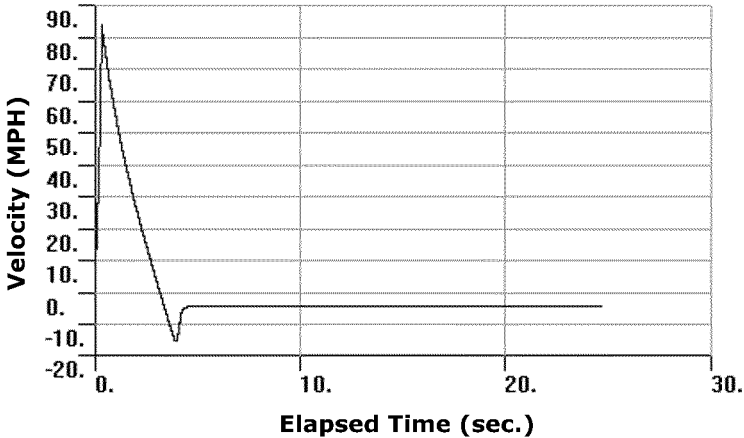

Figure 5.2: Velocity of the rocket during a typical launch

The velocity graph provides two important pieces of data: maximum velocity and descent velocity. For this rocket, the maximum velocity is 84 MPH. This velocity occurs not at apogee, but a few tenths of a second into the flight. Apogee occurs when the velocity is 0 MPH. Once the parachute opens, the rocket slows to its decent velocity, in this case, about -4 MPH. This decent velocity is one of the most critical factors in designing a winning rocket—the slower the rocket falls, the longer it is going to stay aloft.

5.1.3 Acceleration

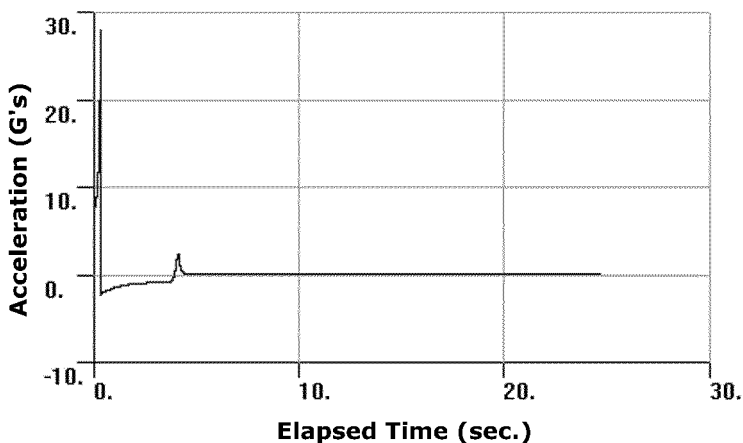

Figure 5.3: Acceleration of the rocket during a typical launch

Notice that the acceleration graph has two spikes in it—a large one a few tenths of a second after launch, and a second, smaller one about 4 seconds into the flight.

The first spike is the important one—it indicates the maximum acceleration of the rocket due to the propulsion of the pressurized air and water. During this launch, the rocket will experience 28 G's, or 28 times the force of gravity, as it ascends. This value is important to consider when building rockets—a small, 30 gram parachute, will have the effective weight of $30 \times 28 = 840$ grams during launch! If the parachute hold is not strong enough to support the weight of 840 grams, it will likely break.

The second spike is caused by the rocket slowing down as the parachute inflates. The value of this spike is typically not important, because it is small compared to the acceleration due to the pressurized air and water.

5.2 Water Volume

Simulators are great for finding the optimum water level for a rocket. Sure, you could test your rocket with various amounts of water to find the optimum level, but that would be tedious. Plus, accurate testing is often not possible, because wind and other uncontrollable factors get in the way.

Finding the optimum water level is important. Most people typically use around 50%, but you can usually get an extra 10 to 20 feet of height by finding the optimum water level (typically 40% to 45% of the bottle's volume). A few feet may not sound like much, but since a typical rocket with a parachute descends at 2 to 3 feet per second, this extra height results in another 5 to 10 seconds of time aloft.

Comparing the two graphs on the next page illustrates an important point about optimum water levels—it varies depending on the rocket. Heavier rockets, and ones with greater drag, require a greater volume of water to reach their maximum height. For most rockets, the optimum volume will be 40% to 45% of the volume of the bottle.

Once you find the optimum water level for your rocket, it is important to be able to consistently measure that volume of water into your rocket. See Appendix A, *Water Markings*, to see a simple system for measuring the water level inside your pressurized bottle.

5.3 Mass

Just as there is an optimum water volume to get the maximum height, there is an optimum mass to reach the maximum height. This optimum mass varies, depending on the rocket's drag.

The optimum mass for rockets is typically very low. Very rarely will you have to add weight to your rocket to reach the optimum mass. Normally, a stable, aerodynamic rocket with parachute weighs more than the optimum mass, but this value

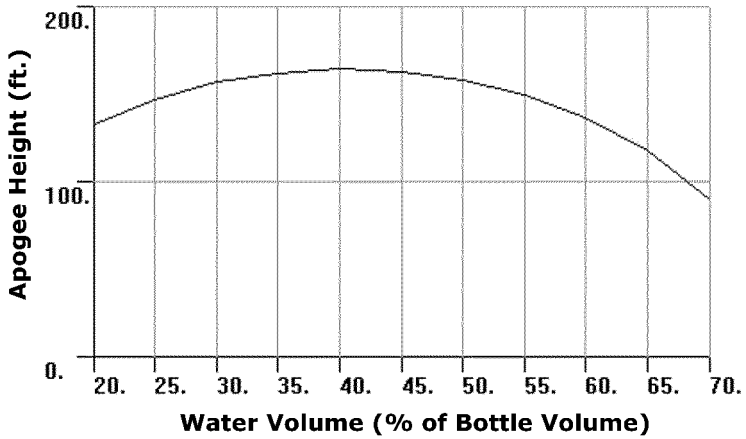

Figure 5.4: Optimizing water volume for a 120 gram, 2 liter rocket

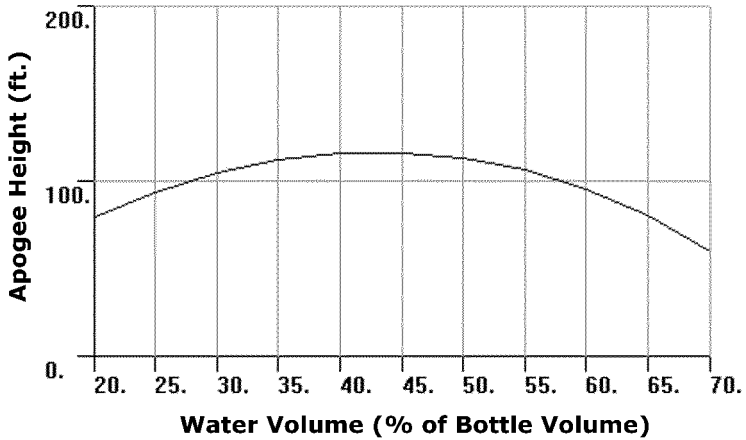

Figure 5.5: Optimizing water volume for a 250 gram, 2 liter rocket

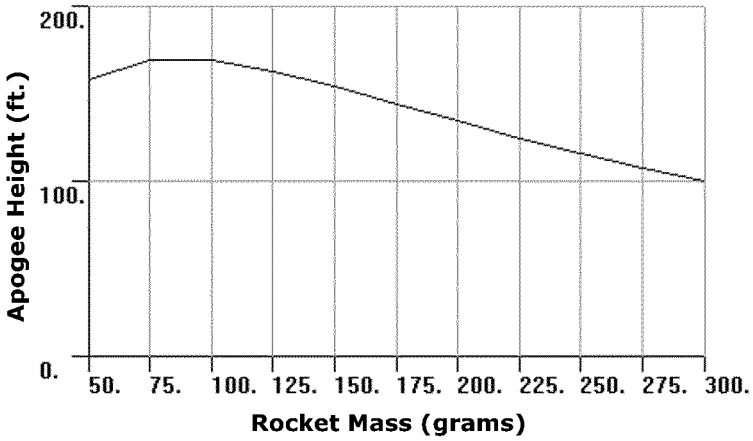

Figure 5.6: Optimizing mass for a 2 liter rocket with 0.2 drag coefficient

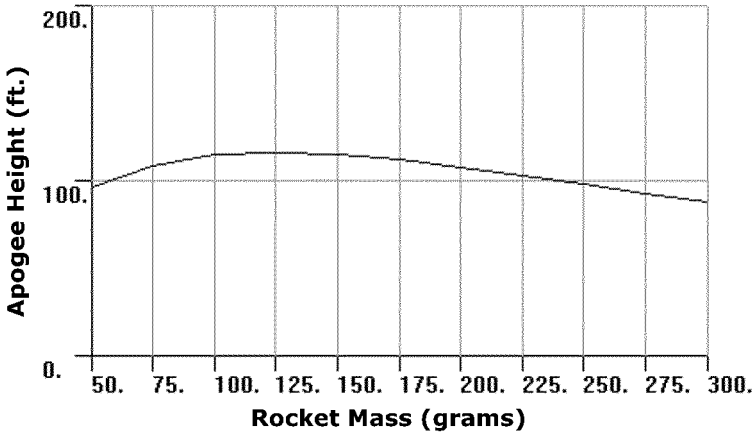

Figure 5.7: Optimizing mass for a 2 liter rocket with 0.5 drag coefficient

will give you a good goal for the weight of your rockets.

As you can see from the graphs on the previous page, the optimum mass for a 2 liter rocket is typically between 75 and 125 grams. These values are deceptive though—these are the optimum masses to get the maximum *height*. The optimum mass to get the maximum *time aloft* is typically much lighter, because weight causes the rocket to fall faster, especially when it is descending with a lot of drag (when the parachute opens). It is better to have a light rocket descend from an altitude of only 100 feet, as opposed to a heavy rocket descending from 120 feet.

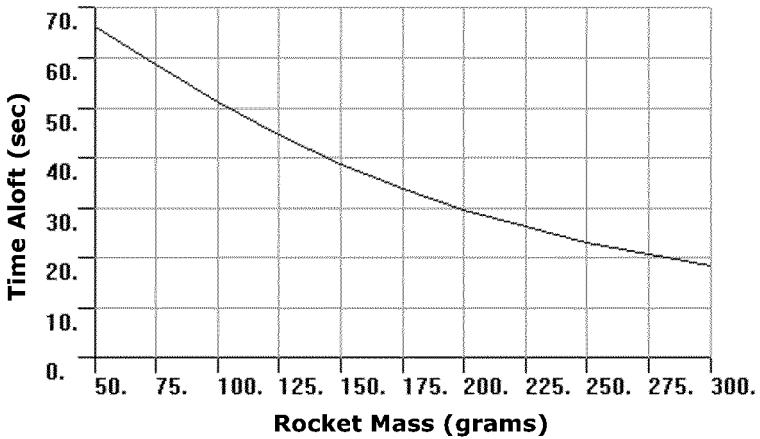

Figure 5.8: Optimum mass can be deceptive—under certain conditions, additional weight will increase height, but it will actually cause the rocket to fall faster.

If your rocket weighs less than the optimum mass, there is a simple solution: bring your rocket up to weight by adding additional parachute. This will not only increase the height of your rocket, but it will also result in a slower descent and longer time aloft.

Part II

Rocket Construction

Chapter 6

Fins

In Chapter 4, we learned to calculate the shape and size of fins for a rocket, but building them can be another challenge.

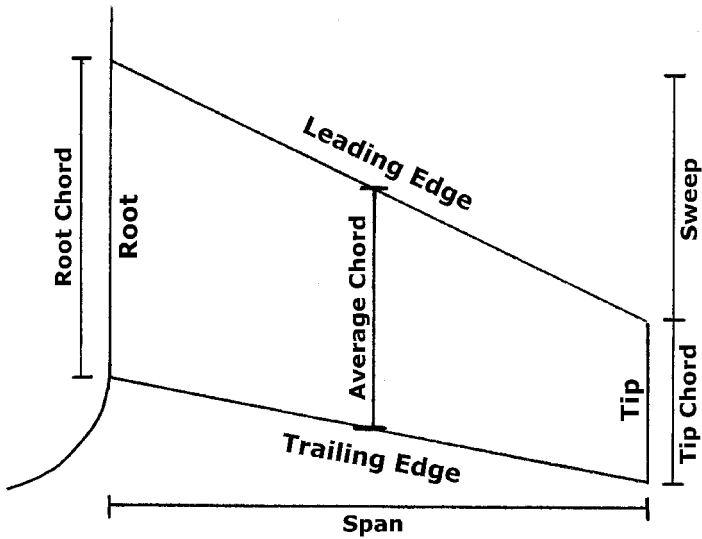

Figure 6.1: Fin Dimensions and Terminology

We will start by looking at the simplest fins, single-ply fins. These work well for rockets which need only small fins to make them stable, but as rockets are built larger and lighter, they require larger fins that must be reinforced. We will look at these “3-dimensional” fins too.

6.1 Single-Ply Fins

A single sheet of light plastic or wood is adequate for most basic fin designs. ($1/16^{\text{th}}$ inch balsa wood works best) They are the simplest and easiest to fins to make, but they have a weakness: plastic will bend and balsa will break.

6.1.1 Fin Patterns

One useful tip before constructing a set of fins is to make a pattern on a sheet of paper. Be sure to keep it in a folder or other safe place, because you will need it to build replacement fins. Single-ply fins usually last only a few launches, so it is best to plan ahead and build extras.

Also, a fin pattern can be useful for building fins with various angles. Simply make a copy of the fin pattern, cut it out, and trace it on to the material.

6.1.2 Constructing

Building fins is simply a matter of taking your time and carefully cutting the balsa with a sharp knife, but there is one important tip when constructing fins: **When using wood, always cut fins with the grain of the wood parallel to the leading edge!** This makes fins much stronger and less likely to break during flight.

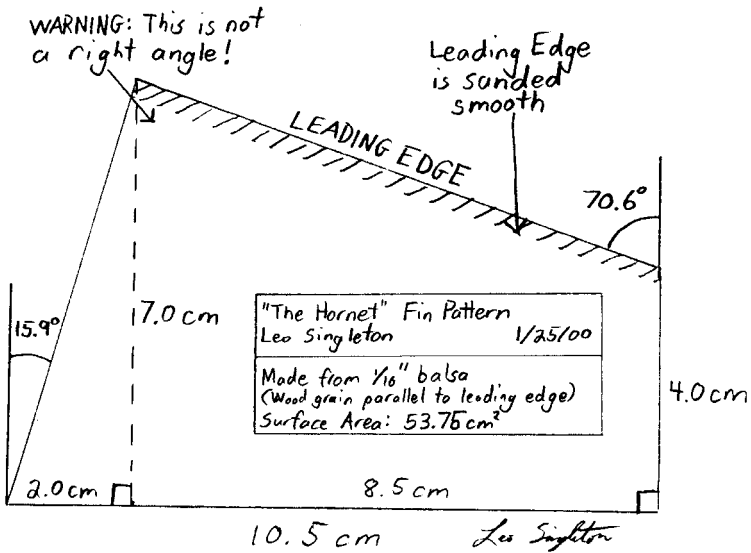

Figure 6.2: A sample, single-PLY fin pattern from *The Hornet*

6.1.3 Breaking Point

As we said before, the downside of single-PLY fins is their low breaking point. As a general rule, on a normal rocket, launched at 60 PSI, the maximum span of a single-PLY balsa fin is between 10 and 15 cm. Remember, this rule applies when the grain is cut parallel to the leading edge. Fins with grains cut in other directions sometimes fail with a span only 5 to 10 cm.

Since the 10 to 15 cm rule applies to 1/16th inch balsa wood, you can sometimes get away with a few extra centimeters of span by using 3/32^{nds}. This is usually not a good idea, because it adds extra drag and weight. 3-dimensional fins are usually a better solution.

An important sign of fins that are approaching their breaking point is "fluttering." Fluttering occurs when the air traveling over the fins causes intense vibrations and will lead to structural failure. Sometimes fluttering is minimal, and only causes a hum-

ming noise as the rocket lifts off, but take this as a warning—when fluttering gets too bad, the fins will rip apart.

6.2 Reinforced Balsa Fins

Reinforced fins, or “3-dimensional fins,” are made of three separate layers of balsa wood glued together to form a strong, but light fin. Reinforced fins have much more strength than single-ply fins, and can be used when extra stability is needed.

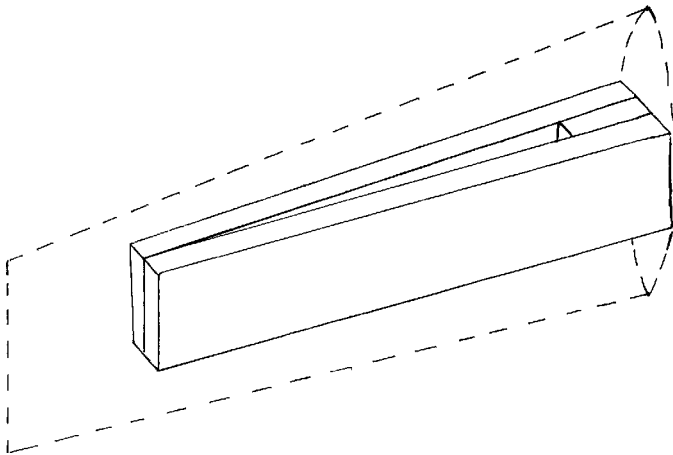

Figure 6.3: Internal balsa structure of a reinforced fin

Reinforced fins are constructed using two strips of $1/16^{\text{th}}$ inch balsa wood, approximately $1/2$ to $3/4$ of an inch in width and have a length of about $2/3^{\text{rds}}$ of the span of the fin. A third, smaller piece of $1/16^{\text{th}}$ inch balsa is placed in between the other two strips, to increase the thickness of the fin at the root. As usual, make sure the grain of the wood is parallel to the leading edge.

The internal structure is then covered with $1/32^{\text{nd}}$ inch balsa wood, which makes up the actual surface of the fin. The two pieces are first glued to the internal structure, then their edges

are glued together. ($1/32^{\text{nd}}$ balsa is very flexible) For decreased drag, the edges of the fin can later be sanded down to a smooth edge.

6.3 Other Materials

Fins do not necessarily have to be made from balsa wood. Balsa is simply a light material that is relatively easy to work with. Any type of plastic, cardboard, or other material can be used for fins, as long as it is rigid. Remember, the stability simulations in the previous chapter *assume* that the fins on the rocket are rigid. Fins that are not rigid will have no effect on a rocket's stability.

6.4 Attaching Fins to Rockets

A good fin is useless unless it is attached to the rocket well. Like a fin, the joint should be rigid, and prevent the fin from moving around. Materials such as duct tape (even aluminum tape) do not work well, because they allow the fin to move back and forth during flight, making the fin useless.

The best way to attach fins to a rocket is by using a strong glue, such as a super glue or hot glue. Medium-set Jet glue works best.

Unfortunately, Science Olympiad rules prohibit using super glues or hot glues directly on the pressurized bottle. We can work around this by cutting strips of plastic from another bottle. The strips should be the length of the fin, and about one inch wide. **Before using super glue on the plastic, be sure to thoroughly sand it with a light sandpaper (500 grit or lighter), until the plastic becomes translucent.** Otherwise, the glue will not stick to the plastic! Apply a few drops of glue to the plastic and set the fin in place. Once the glue hardens, apply a full bead of glue to each side of the fin for extra strength.

Now you can attach the strips of plastic to the rocket using mailing or packaging tape. (Scotch extra-strength mailing tape

works well.) **When taping fins to the rocket, be sure to completely cover the top of the plastic strip with tape!** If the top of the strip is not taped, air can get underneath during launch, and the fin will rip off.

6.5 Extra Reinforcement

Although super glue works well for attaching fins to rockets, this joint can never be too strong. Remember, by Science Olympiad rules, if the fin breaks off during launch, the rocket is automatically disqualified.

For extra reinforcement, a flexible, caulk-like glue works well. After the super glue has dried, run a small bead along each edge of the joint, and let it dry for at least 24 hours.

Chapter 7

Parachutes

Once we have covered the basics, and can build a rocket that is stable, it is time to start working on the next aspect: parachutes. A simple plastic bag will work if you're only looking for a few seconds aloft, but a competitive rocket requires a much better parachute. As you will see, building a good parachute can be as complicated as building the rocket itself.

7.1 Dome Parachutes

First, we will look at dome parachutes. These parachutes are made from multiple panels of fabric, sewn together to form a dome shape—far more efficient than the typical flat parachutes used in model rocket kits.

Parachutes work by trapping air to create drag. For a flat parachute to work, it must first inflate, by forming a domed shape to catch the air. When this happens, only half of the parachute is used to trap air, while the other half flaps around uselessly. A dome-shaped parachute solves this by “fitting” the shape of the air, so all of the parachute's surface area is used.

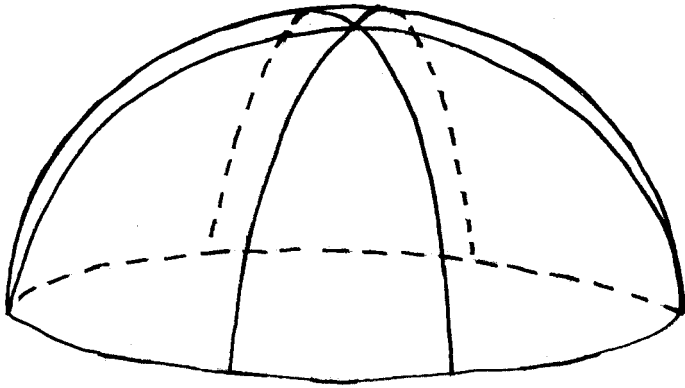

Figure 7.1: A 6-panel dome-shaped parachute

Dome-shaped parachutes are constructed out of three or more pieces of material (usually plastic). These panels are attached together like a beach ball, with panels attached side to side, with every panel meeting at a single point at the top. There is no exact formula for determining the number of panels needed for a parachute, but here are some typical values:

Parachute Diameter	Parachute Type	Typical Number of Panels
< 40 cm	Small Drogue	4
40 - 60 cm	Large Drogue	6
60 - 100 cm	1-Liter	8
100 - 130 cm	2-Liter	8

A top view of the parachute shows how the panels are connected. The panels of a 6-panel parachute appear to be six triangles, but the panels are not actually triangular. They are flattened out *spherical triangles*—the sides are no longer straight when mapped in two dimensions.

Although dome-shaped parachutes work extremely well, there is still a way to improve them further: elliptical parachutes.

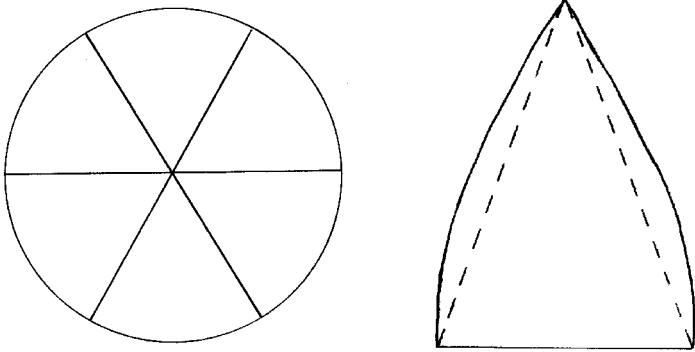

Figure 7.2: Left: A top view of a 6-panel dome-shaped parachute. Right: A single panel of the same parachute. Notice that the panel is no longer triangular-shaped when it is laid flat.

7.2 Elliptical Parachutes

Elliptical parachutes are essentially stretched-out versions of dome parachutes. They allow the parachute builder to make a larger parachute with the same amount of material. Thus, elliptical parachutes are lighter and deploy faster than their equivalent dome-shaped parachute.

In a dome-shaped parachute, the radius equals the height, but in an elliptical parachute, the height is less than the radius (typically 70% of the radius). This ratio has a give-and-take effect. As the height decreases, the parachute requires less material, but loses efficiency. Eventually, if the height is decreased all the way to zero, we are back to a circular parachute.

7.3 Constructing a Panel

The first step in building a parachute (either dome or elliptical) is to build a pattern for one panel of the parachute. For now, we will assume that you already have the coordinates that form the

curve of your panel—in Part III you will learn how to calculate coordinates for parachutes of any shape and size.

Here is the output from a parachute calculator. We will use these values to construct our pattern:

Diameter: 100 cm
Height: 50 cm
Bottom Overhang: 10 cm
of Panels: 8
of Calculated Points: 10

Panel Coordinates:

(+/- 0.00 cm, 78.54 cm)
(+/- 3.41 cm, 69.81 cm)
(+/- 6.72 cm, 61.09 cm)
(+/- 9.82 cm, 52.36 cm)
(+/- 12.62 cm, 43.63 cm)
(+/- 15.04 cm, 34.91 cm)
(+/- 17.00 cm, 26.18 cm)
(+/- 18.45 cm, 17.45 cm)
(+/- 19.34 cm, 8.73 cm)
(+/- 19.63 cm, 0.00 cm)

Vertex of Overhang Arc: (0 cm, 14.28 cm)

Radius of Arc: 24.28 cm

Angle of Arc: 1.8842 radians

To construct our pattern, first, find a large enough piece of posterboard. (You can use heavy paper, but posterboard works best) Also, this posterboard needs to be white, or another light color—you will be making a lot of pencil marks on it before we get to our actual shape.

To determine the size we need, look at our panel coordinates: the x values range from -19.63 to 19.63 , thus we need a width of about 40 cm. Our y values range from 0 to 78.54, but notice that we have an overhang of 10 cm, so we actually need a height of about 90 cm.

Once we have our posterboard, we need to draw our x- and y-axis. It is important that these are perpendicular, because we will base all of our other measurements on them. Make sure that they are perpendicular by using the corner of a sheet of paper to mark the right angle. As we stated before, our x-axis needs to range from -19.63 to 19.63 cm, and our y-axis needs to range from -10 to 78.54 cm. You can always make the axes longer than these measurements—those are just how much our pattern will occupy.

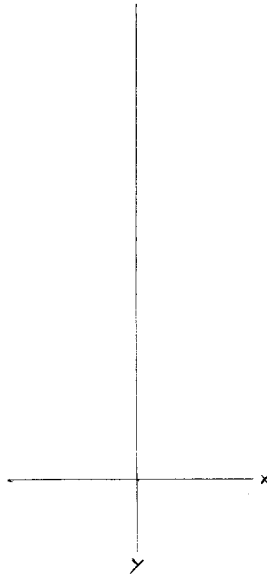

Figure 7.3: Axes for our 100 cm dome parachute

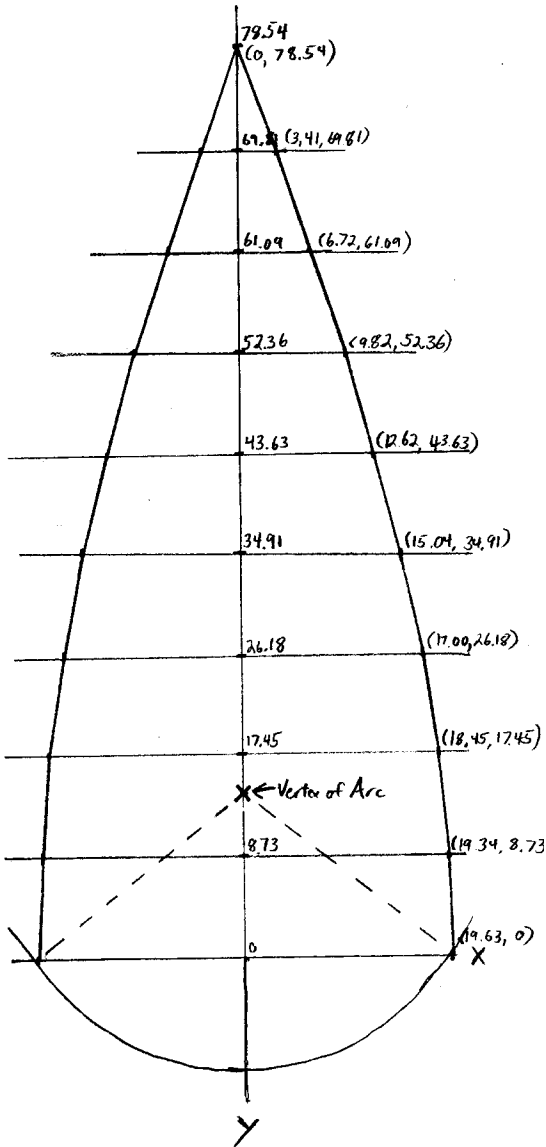

Figure 7.4: Completed pattern for a 100 cm dome parachute

Once we have our axes, we can mark off our y values on our y -axis. These should be equidistant, as we will show in our next chapter.

Once we have our y values marked, the next step is to measure out the corresponding x values and mark our points on the posterboard. Connecting these points should give us the curved sides of our panel.

Finally, we construct our overhang. Overhang is an arc, so we must first find and mark this coordinate, $(0, 14.28)$, on our posterboard. Next, construct the arc using a compass. If it is large parachute, as in this case, a standard compass will not be large enough. You will have to use two pencils and a piece of string. (A piece of posterboard with holes punched in each end also works well.)

Now, we can cut out our pattern and use it to trace onto our panel material. Use a dark marker to trace your pattern onto your material. When cutting, **do not cut directly on the lines!** You must leave room for a seam to attach panels with. The width of this seam depends on the method you will be using to attach panels together. Also, if you will be using a soldering iron or wood burner, you will cut the panels and melt them together at the same time, so do not cut them out yet.

7.4 Methods of Construction

7.4.1 Glue or Tape

Glue or tape can be used to attach panels together, but it does not work well. Tape and glue both add a great deal of weight to the parachute, and make the parachute stiff.

7.4.2 Iron

Panels can be melted together using an iron. Place two panels, one on top of another, on an ironing board, and place your posterboard pattern between the two pieces of plastic. This will

prevent the panels from melting together anywhere except for the seams, which will be hanging over the edge of the pattern. Cover both of these with a cloth or towel, and then iron the seam for 10 to 20 seconds. Allow a few seconds for the plastic to dry, then pull out the towel and the pattern. The plastic panels should be melted along the seam into a single piece of plastic. If not, repeat the same process and try again.

7.4.3 Soldering Iron or Woodburner

The best way to attach panels together is to use a low-power soldering iron or woodburner. This method creates the smallest seam, compared to the other methods, and thus, creates the lightest parachute with the most flexibility.

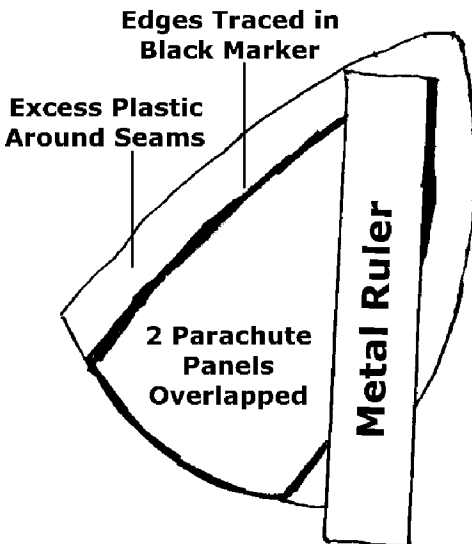

Figure 7.5: Using a metal ruler and soldering iron to attach parachute panels

If your soldering iron or woodburner is too hot, causing the plastic to melt too fast, you can reduce the power by installing a dimmer switch, used for lights, to reduce the power.

Take two panels (do not cut them out), and lay them on top of each other so that the lines you traced from the pattern overlap. Working piece-by-piece along the curve, take a metal ruler and hold it along the line. While pressing down on the metal ruler, run the soldering iron along the ruler's edge. It should make a nice cut, approximately 1 mm in width, and in the process, it will melt the edge of the two pieces of plastic together. If the soldering iron cuts through the plastic without melting the panels together, increase the temperature of the soldering iron.

Repeat this process to attach all of the panels together, making sure that the seams are all on the same side. If the parachute is made carefully enough, the tops of the panels will meet in a single point, and a top panel will not be needed.

7.5 Shroud Lines

Shroud lines are attached to the bottommost point on each panel of the parachute (in the overhang area). The very purpose of the overhang is to attach shroud lines—they help to distribute the force of the shroud lines, and prevent them from pulling the parachute closed.

To attach shroud lines, first place a piece of tape where you want to attach the line. Do this on both sides of the plastic. Then, use a hole punch to cut a hole through both layers of tape and the plastic. **Do not use scissors to cut the hole!** A round hole is less likely to tear when the shrouds are pulled tight.

For an even stronger hole for attaching shrouds, touch the tape with a hot woodburner or soldering iron. This will melt a hole through the parachute and both pieces of tape, but it will also cause some of the plastic to bead up around the edge of the hole. Once cooled, this will form a hard, protective ring and prevent tearing of the parachute.

Many different materials can be used for parachute shroud lines. Most types of string work fine, but of course, the stronger and lighter, the better. Do not use fishing line. Fishing line tends to hold its shape, and not want to flex. It is more likely to get caught or tangled than regular string.

Dacron is one of the best shroud materials available, not only because it is strong and light, but because it does not hold its shape when coiled for a long period of time. Dacron can be found in many stores and hobby shops, often sold as kite string.

Shroud length is also an important consideration. Typically, shrouds should be 2 to $2\frac{1}{2}$ times the diameter of the parachute, but this is often not practical for Science Olympiad rockets, which have a maximum length of 3 meters. Usually, shrouds that are 1 to $1\frac{1}{2}$ times the diameter will suffice, and allow you to put the largest parachute possible within the 3 meter limit.

Chapter 8

Parachute Deployment Systems

The best parachute is dead weight without a good parachute deployment system. This is the most critical part of any rocket, since it determines the difference between a one minute launch and a six second launch.

There are many different methods for deploying a parachute on a bottle rocket, ranging from the simplest gravity system to a complex airspeed flap design. We will look at both of these deployment systems and how they work.

These are not the only two reliable ways to deploy a parachute. Other methods, such as using a balloon or wind-up timer, can be found on the Internet. See the *Further Reading* section for helpful links to get started.

8.1 Gravity Deployment

The theory behind gravity deployment is simple: heavier things fall faster¹. Therefore, if the rocket body weighs 60 grams, but

¹The laws of physics may appear to contradict this statement, but only in a vacuum. When forces such as wind resistance are taken into consideration, heavier things fall faster

the nosecone weighs 80 grams, the nosecone will fall faster, separating from the parachute. Then, if the length of the string attaching the nosecone to the body of the rocket is longer than the total length of the parachute (including shrouds), the parachute will deploy.

This system is the “quick and easy” way to get a parachute deployed on a bottle rocket, but it has three major downsides: First, this system is not very reliable—even if you have a great difference in the weight of the body and nosecone, there will still be occasional failures for no reason. Second, this system requires a long string for the nosecone, which under the Science Olympiad limit of 3 meters, drastically reduces the parachute size that you can use. Third, rockets that use this system are *heavy!* For a reliable rocket, you will need the weight of the nosecone to the body in at least a 2:1 ratio (e.g. a 200 gram nosecone with a 100 gram body). The very principle that makes this system work is what makes it so unusable—a 300 gram rocket falls fast, even with a parachute².

8.2 Airspeed Flap Deployment System

The airspeed flap solves all the problems of gravity deployment—once it is finely tuned, it is extremely reliable, adds no additional length to the rocket, and it adds only a mere 5 to 10 grams to the weight of the rocket.

The airspeed flap was originally designed by Dave Johnson, but there are now many variations of its design. The design presented here is a unique variation developed by Columbus High School. For more information on Dave Johnson’s original system, you can find the address of his web site in the *Further Reading* section of the handbook.

²Our record for a gravity-deployed rocket is 23 seconds

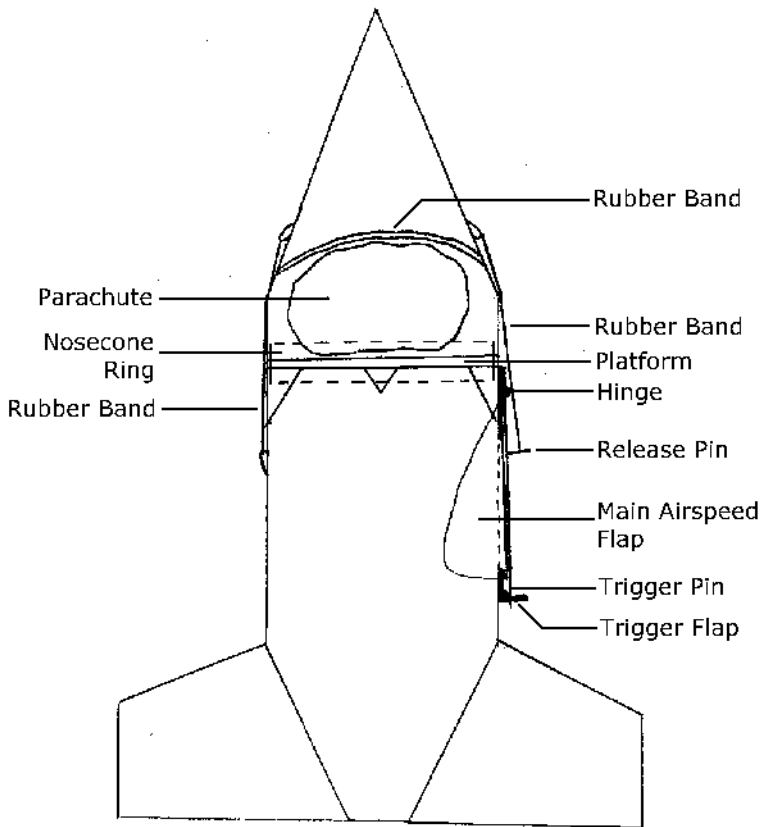

Figure 8.1: A typical Airspeed Flap Deployment System

The main component of this system is the airspeed flap—a small flap of plastic (made from the mid-section of an empty bottle) that is hinged at the top and attached to the side of the rocket body. This airspeed flap will be held against the rocket body by the force of the wind during launch. At apogee, the wind will no longer be strong enough to hold the flap down, so it will open, and release the nosecone.

To prevent the main airspeed flap from deploying while the rocket is on the launch pad, a trigger flap is used. The trigger flap is released by the force of the wind from liftoff.

The nosecone sits on top of the rocket, and is held in place by two rubber bands—one on each side. One rubber band is attached to the rocket body, while the other is hooked on to the main airspeed flap. These rubberbands work as opposing forces—if they are tensioned properly, they will hold the nosecone in place during the launch. Once the main airspeed flap opens, the rubber band attached to it will be released. The nosecone will be pulled off by the rubber band on the other side, releasing the parachute.

8.2.1 Platform

Before constructing an airspeed flap deployment system, you must first flatten out the top of the rocket body using a platform made of light cardboard or plastic. The parachute will sit on top of this platform.

To prevent the nosecone from slipping off of the platform during launch, cut a small ring out of the mid-section of another bottle. Mount the ring around the platform, leaving only $1/8^{\text{th}}$ to $1/4^{\text{th}}$ of an inch protruding above the platform.

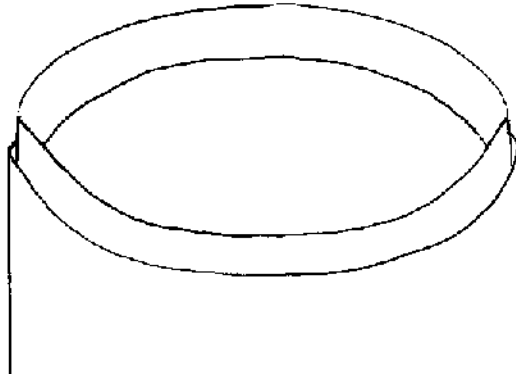

Figure 8.2: A platform with nosecone ring

8.2.2 Nosecone

As stated above, the nosecone should have a rubber band attached to each side of it—one will be attached to the rocket body; the other to the main airspeed flap. Place another rubber band on the inside of the nosecone. Once there is a parachute on the platform, this rubber band will act as a “spring” to push the nosecone off. For even better results, use two rubber bands on the inside, and attached them in a cross.

8.2.3 Main Airspeed Flap

The main airspeed flap is constructed from the mid-section of another bottle and hinged at the top. The main airspeed flap should have two pins attached to it. You make these pins from paperclips or wire, or you can replace the pins with plastic to avoid using metal parts. The first pin is located near the top, and is perpendicular to the surface of the flap. This pin will be used to hook the rubber band going to the nosecone. The second pin is located at the bottom of the flap, pointing down. The purpose of this pin will be explained in the next section on the trigger flap.

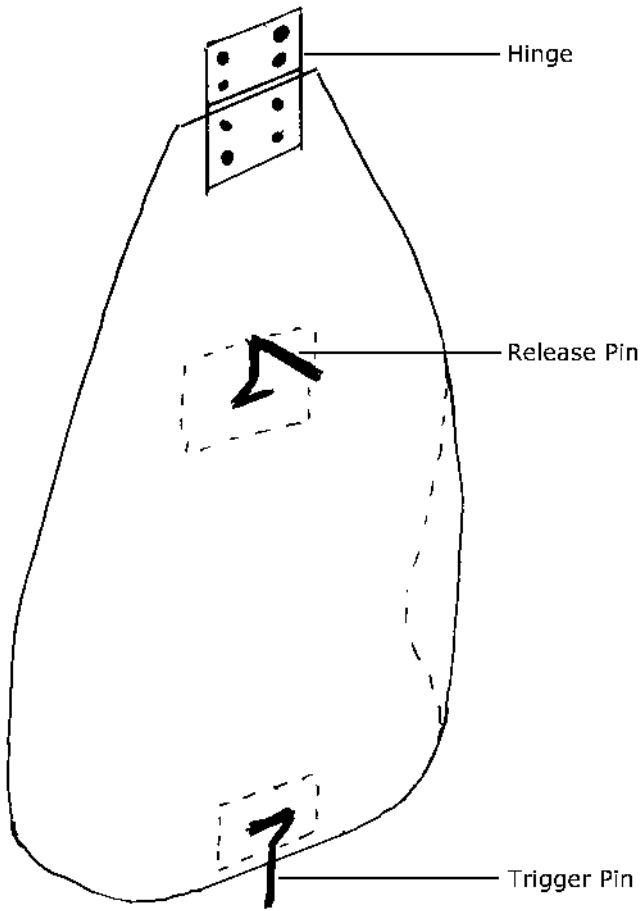

Figure 8.3: Main Airspeed Flap

8.2.4 Trigger Flap

The purpose of the trigger flap is to hold the main airspeed flap down while the rocket is on the launch pad. It can be made of a small hinge, with a hole drilled on one side. The pin from the bottom of the airspeed flap can be placed through this hole to hold the main flap in place. During launch, the trigger flap will be forced down by the wind, releasing the main airspeed flap.

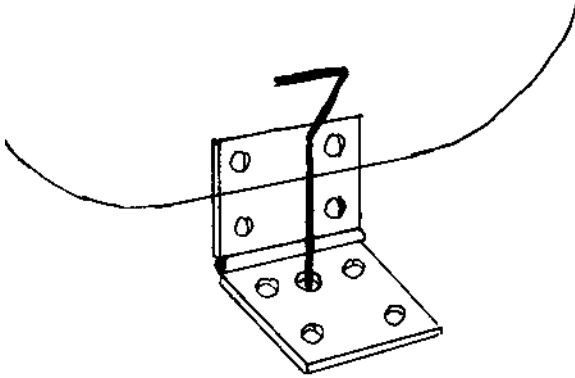

Figure 8.4: Trigger Flap and Trigger Pin

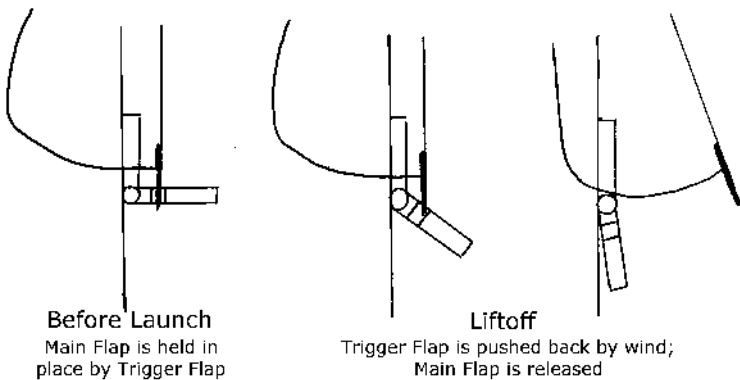

Figure 8.5: The Trigger Flap releases the Main Airspeed Flap

8.2.5 Tensioning the Rubber Bands

The airspeed flap deployment system only works if the rubber bands are tensioned properly. The best way to test it is by setting the main airspeed and trigger flaps, then blowing on the flaps to simulate the wind from the launch. With one large breath, you should be able to release the trigger flap and still hold the main airspeed flap down. If the rubber bands are tensioned right, the nosecone will spring off as soon as you stop blowing on the main airspeed flap. If not, try different combinations of rubber bands to get the right tensions.

8.3 Airspeed Flap With Drogue

To further improve the airspeed flap design, we can add a second parachute compartment and a drogue parachute to the design. A drogue parachute (typically 30 to 50 cm in diameter) is designed to deploy quickly. When it is attached to the top of the main parachute, the drogue will help to inflate the main parachute faster. For consistent, quick deploys of large parachutes, use an airspeed flap to deploy the drogue chute and let the drogue pull the main chute out of its compartment.

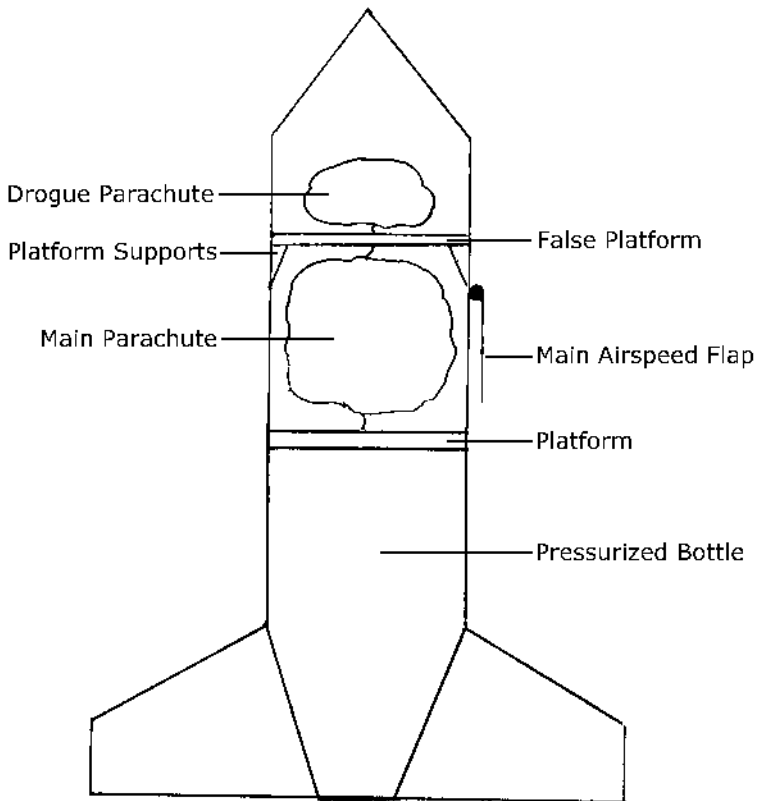

Figure 8.6: Typical Airspeed Flap Deployment System with Drogue Parachute

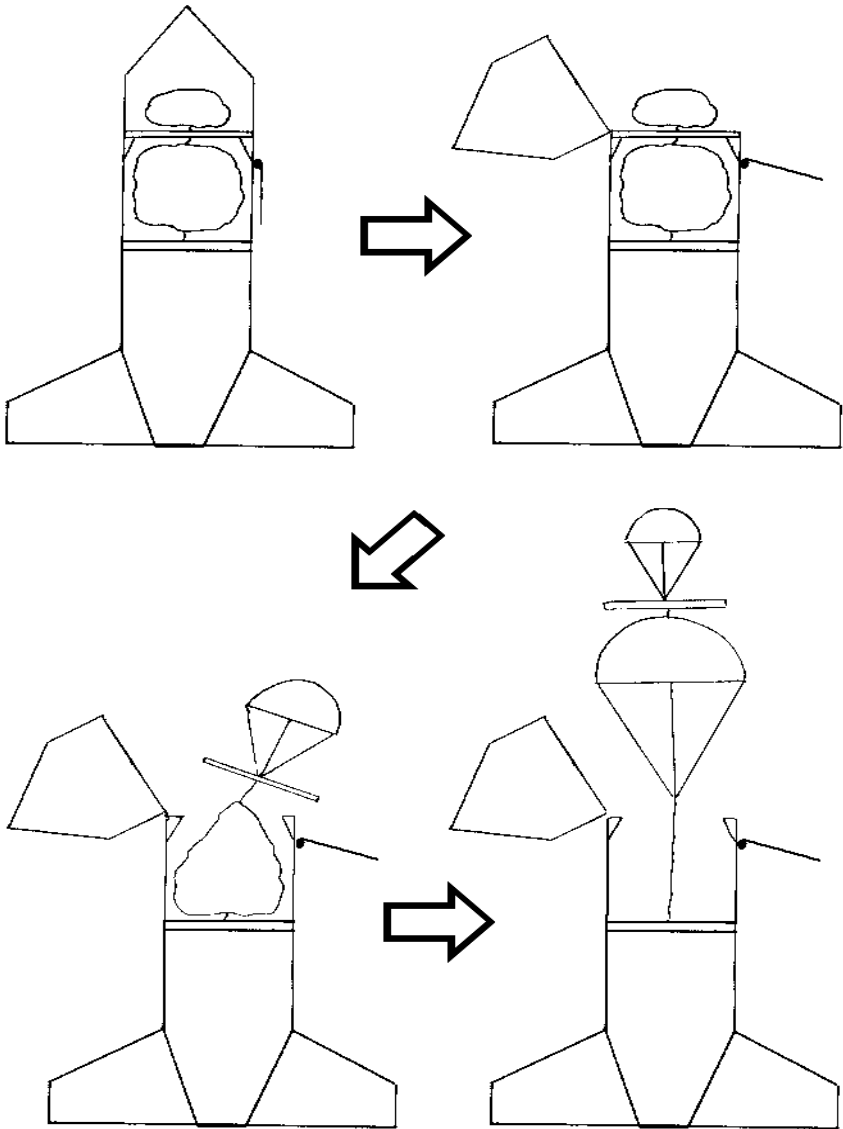

Figure 8.7: Main Airspeed Flap releases nosecone; Drogue Chute pulls out False Platform and inflates Main Parachute

Chapter 9

More Parachute Tips

9.1 Packing Parachutes

The best way to pack a parachute is using the “z-fold.” Hold the parachute from the top and stretch it out into a long roll. Then, fold the parachute back and forth every two to three inches, depending on the size of your parachute hold.

At competition, it may be necessary to pack your parachute before competition, hours before it is actually launched. If this is the case, sprinkle baby powder over the entire parachute (inside and outside) before you fold it, and continue to sprinkle baby powder as you fold the parachute. Baby powder will help prevent the plastic from sticking together. It is best to test this a few times before competition, to make sure the parachute does not expand or get stuck in the parachute hold.

9.2 Testing Parachutes

Sometimes, you may have to test your rocket in less-than-ideal conditions. If the wind gets too heavy, and could possibly blow the rocket into nearby trees or obstructions, it is best to test the rocket without using full parachutes. Testing with smaller parachutes is a possibility, but on light rockets, parachutes are

used as ballast, and they are critical to a rocket's stability. It is better to test with full parachutes, while restricting the parachute from fully opening with a twist-tie. To do this, stretch the parachute out, as if you were about to do a z-fold. Take the twist-tie, and tie it around the middle of the parachute. This will restrict the parachute to approximately a third of its normal surface area. If you need to use even less parachute area, move the twist-tie down further.

9.3 Multiple Parachutes

Multiple parachutes are possibly a way to get more parachute surface area, but they create many additional problems, and are probably not worth the effort.

On multiple-parachute rockets, there is a good chance that one or more of the parachutes will get tangled. Extra precautions must be taken when folding parachute shrouds.

Another serious problem is that on a multiple-parachute rockets, the parachutes usually inflate at different times. Often, only one will inflate for the first five to ten seconds of flight, because it reduces the speed of the rocket, which prevents the other parachutes from inflating.

9.4 Parachute Age

It is important to keep track of parachutes ages and the plastic that they are made from. Mixing parachutes of different ages (either as multiple parachutes or a main-drogue combination) can cause problems. As parachutes age, they become stiffer and require a greater velocity to inflate. Often, only the newer parachutes will deploy, causing the older parachutes to become dead weight that only increases the chances of getting the parachutes tangled.

9.5 Shroud Tangling

Shrouds getting tangled can be a problem in rockets. For multiple-parachute rockets, it is best to keep the shrouds in different parachute compartments. For single-parachute rockets, the best solution is to attach a fishing swivel between the shrouds and the rocket body. This will allow the parachute to roll and spin as it inflates, without tangling the shroud lines.

Chapter 10

Nosecones

There are two theories to nosecone design:

1. Make it as heavy as possible.
2. Make it as light as possible.

The reasoning behind the first theory is stability—by adding weight to the nose of the rocket, you move the center of gravity forward, increasing the rocket’s stability. This is the “quick-and-easy” way to build a rocket, but it has a major downfall—you won’t get over a few seconds aloft, because the rocket is simply too heavy.

Since you’ve already read this far into the handbook, you’re obviously not looking for the “quick-and-easy” way to build anything. Instead, we’ll look at making nosecones light and strong.

10.1 Materials

Selecting the right material is the key to building a light nosecone. Pieces from plastic bottles tend to work well, as long as you do not use the nozzle section or the base of the bottle—these are the heaviest sections (See Appendix C for more information on bottle weights).

If you decide to use part of a 2 liter bottle as a nosecone, be sure to cut off the top 4 cm of the nozzle. To cover the hole, you

can make a small cone out of the mid-section of a bottle. Simply take a piece of plastic from a bottle, roll it into a conical shape, and attach it with glue or packaging tape.

To make your nosecone even lighter, thoroughly sand it with 100 grit sandpaper. (Remember: **Sanding on the pressurized bottle is not allowed**, but you can do whatever you want to nosecones and other parts) You can typically reduce the weight of the cone by 30% to 50% by sanding. After doing this, the plastic will become very rough—use a lighter grain of sandpaper (500 to 1500 grit) to make the plastic smooth.

10.2 Aerodynamics

The nosecone is the most important part of a rocket's aerodynamics. It is critical that the nosecone is rigid, because the rocket will experience 80 to 100 MPH of wind as it is launched—paper or other weak materials will not help to deflect the wind under these speeds.

Shape of the nosecone is also important to reduce drag. The best way to test nosecone shape is using a wind tunnel, but we will not cover wind tunnels in the handbook. More information, including plans to build your own wind tunnel, can be found on the Internet.

Part III

Mathematical Calculations

Chapter 11

Dome Parachute Calculations

This chapter on dome parachute calculations is here as an introduction to constructing 3-dimensional parachutes. The algorithms in the next chapter, *Elliptical Parachute Algorithms*, can calculate both elliptical and dome parachutes, but those are far more complex and much harder to learn. The calculations in this chapter are much simpler, and will work well enough for most students.

In the Chapter 7, we looked at how to construct elliptical and dome parachutes—they are made up of multiple panels in the shape of spherical triangles. The purpose of this chapter is to calculate the shape of these spherical triangles. In this chapter, we will calculate an 8-panel, 100 cm diameter dome parachute.

First, we look at our parachute through its vertical cross-section—a semi-circle. The first step in calculating our panel is find its length. This is easy enough, since the panel occupies half of our semi-circle. Thus, the panel length, P_l , is

$$P_l = \frac{\pi d}{4}$$

where d is the diameter of of the parachute. For our parachute, this formula gives us a panel length of approximately 78.5 cm.

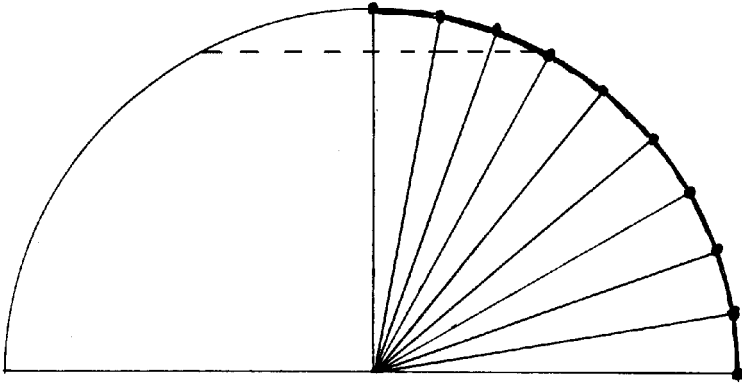

Figure 11.1: Equally-spaced points on the vertical cross-section of a parachute

Next, we must calculate some equally-spaced points along one side of the semi-circle. The number of points you calculate depend on how accurate you want your panel to be. Typically 10 to 20 points is sufficient. The purpose of these points is to serve as reference points for the rest of our calculations.

To calculate these points, first divide 90° by one less than the number of points you wish to calculate. We will use 10 points, giving us a result of 10° . This means that our points are at multiples of 10° : 0° , 10° , 20° , \dots , 80° , 90° . These angles are measured from the origin of the semi-circle.

Since these points are equally-spaced along our horizontal cross-section, they will also be equally-spaced along our final panel. The distance between each point can be calculated by taking the panel length, P , and dividing it by the number of points minus one. For our parachute, the distance between points is $78.5/(10 - 1) \approx 8.7$ cm. The y-values of our parachute are multiples of this number: 0.0, 8.7, 17.4, \dots , 69.8, 78.5 cm¹.

¹Notice that 78.5 is not a multiple of 8.7. This is due to a rounding error—you must actually use the full decimal value, 8.7222... , when calculating your y-values.

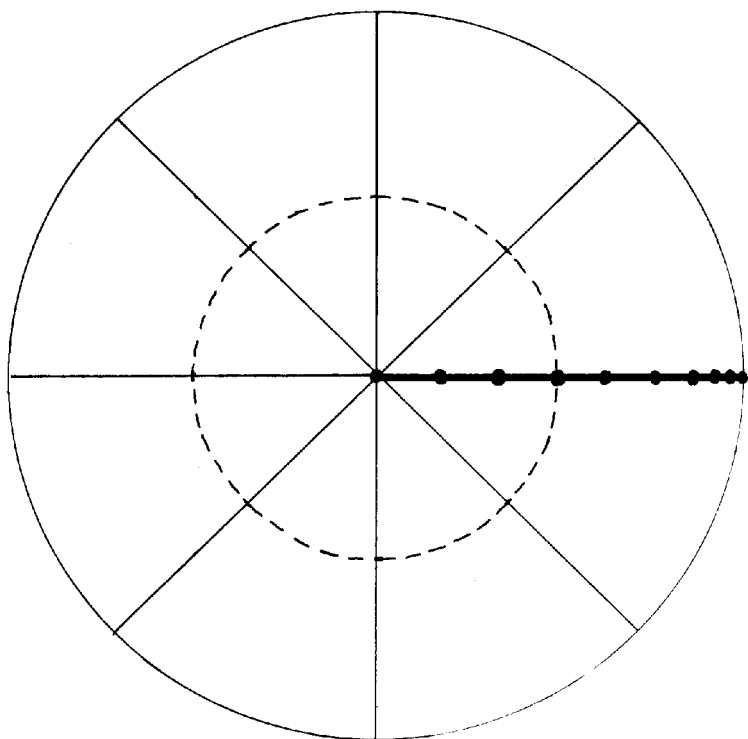

Figure 11.2: Equally-spaced points along the horizontal cross-section of a parachute

Next, we will look at the horizontal cross-section through each of these points. The parachute, like the skin of an onion, forms circular rings when it is sliced horizontally. Also, these rings have an important property: they pass through each panel of the parachute equally.

As far as calculating these rings, we must go back to the vertical cross-section to first find their diameter. The formula uses basic trigonometry, so its derivation will not be shown here:

$$d_{\text{ring}} = d \cos \theta$$

d is the diameter of the parachute. θ is one of the angles calculated above.

We must calculate the diameter for every one of the equally-spaced points shown above. For our 100 cm parachute, you should get the following values for the diameters: 100.0, 98.5, 94.0, ... 17.4, 0.0 cm.

We can calculate the circumference of each of these circles using the formula, $c_{\text{ring}} = \pi d_{\text{ring}}$, then divide each of these values by the number of panels to get the length of the arc passing through one panel. For our parachute, you should get the following values: 39.2, 38.7, 36.9, ... 6.8, 0.0 cm.

We're almost done! These arcs, when mapped our 2-dimensional panel, will become straight lines. Our panel is symmetrical over the y -axis, so we can calculate our x -values by dividing the arc lengths by two. Pairing these with the y -values calculated earlier gives us our final panel coordinates: $(\pm 19.6, 0.0)$, $(\pm 19.3, 8.7)$, $(\pm 18.5, 17.4)$, ... $(\pm 3.4, 69.8)$, $(\pm 0.0, 78.5)$.

Chapter 12

Elliptical Parachute Algorithms

We showed how to calculate points for a dome parachute in the previous chapter, but how can you calculate points for an elliptical parachute? The technique is very similar: we make a parachute panel by first calculating the points on a vertical cross-section of the parachute, which forms the top half of an ellipse (hence the name “elliptical parachute”). Once we have the points on a vertical cross-section, we take a horizontal cross-section of the parachute at each of the points we calculated. Since a horizontal cross-section is a circle, the radius is the distance from the point to the y-axis on the vertical cross-section. And once we have the circle, we can find the circumference, and divide the circumference by the number of panels to find the width of the panel at that point.

The trick is in calculating the equidistant points around the ellipse. The equations for an ellipse are covered in any good math book, but for this application, we must go a step further. There is no exact, mathematical method for calculating equally-spaced points on an ellipse, so we must develop an algorithm to estimate the coordinates.

12.1 Tangent Points Algorithm

The Tangent Points Algorithm is a recursive formula for calculating equidistant points on an ellipse by using derivatives to determine the slope of the tangent line through any point. It requires a basic knowledge of calculus. See the next section for another algorithm, although not as accurate, that does not require any calculus.

Since these points are equidistant, we can refer to the distance between them as a constant¹, z . Once we calculate our z value and have one point on the ellipse, we can estimate the point adjacent to it by constructing the tangent through the point, with a length of z . Mathematically, this cannot actually be a point on the ellipse, since tangents only touch one point, but if we calculate enough points, the points will fit the ellipse close enough for our purposes.

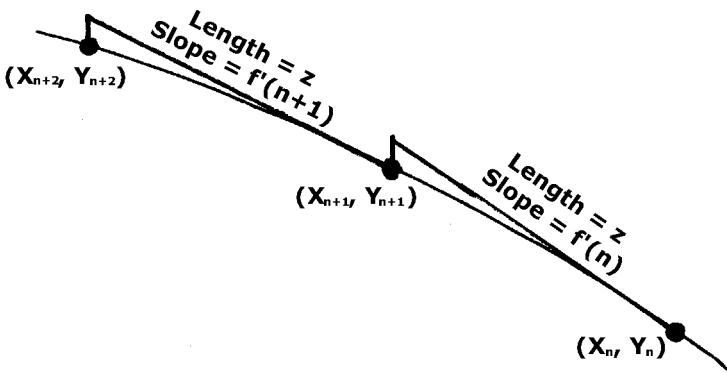

Figure 12.1: Estimating equidistant points using tangent lines

¹The constant, z , is different for every parachute.

Let's start by looking at the variables that are inputs:

Variable	Description	Unit	Range
d	Diameter	cm	$d > 0$
h	Height	cm	$h > 0$
P_n	Number of Panels		$P_n \geq 3$
o	Overhang	cm	$o \geq 0$
p	Number of Points		$p \geq 3$
s	Seam Width	cm	$s \geq 0$
f	Precision Factor		$2.0 \leq f \leq 10.0$
M_t	Material Thickness	cm	$M_t > 0$
M_d	Material Density	g/cm^3	$M_d > 0$

Next, we'll calculate some other variables:

Var.	Description	Unit	Formula
r	Radius	cm	$r = \frac{d}{2}$
P_l	Panel Length	cm	$P_l = \left(\frac{\pi}{4}\right) \left(3[r + h] - \sqrt{(r + 3h)(h + 3r)}\right)$
F	Precision		$F = 10^f$
c	Number of Calculated Points		$c = F \cdot (p - 1) + 1$
z	Distance Between Points	cm	$z = \frac{P_l}{c}$

Radius should be self-explanatory.

Panel Length is $1/4^{\text{th}}$ the circumference of the ellipse². The formula is based upon Ramanujan's formula for the circumference of an ellipse.

Precision, and its cousin, Precision Factor, have been arbitrary values up until this point, but they become very important when determining the number of points to calculate. As stated earlier, we actually calculate many more points than we use, to make the points fit the ellipse closer. The multiple which we use

²Be careful not to confuse the circumference of the ellipse with the circumference of the opening.

is called Precision, and Precision Factor is simply a logarithmic scale of Precision. These variables should be set as high as possible, considering the speed of your computer, to get an accurate computation. The higher these numbers are, the more accurate the panel will be, but it will take longer to calculate.

And finally, we calculate our z , which tells us how long we need to make our tangents.

Before we go any further, we must explain a bit of the notation that will be used in the next sections. The lowercase letters x and y denote coordinates on the vertical cross-section of the parachute, and the uppercase letters X and Y denote the x- and y-coordinates on the pattern for the panel. Points that are being calculated are denoted as (x_n, y_n) , and this point on the vertical cross-section corresponds to the point (X_n, Y_n) on the panel. The point adjacent to (x_n, y_n) on the ellipse, which would be located above this point on the panel, is denoted (x_{n+1}, y_{n+1}) . Also, the notation $(x_n, f(x_n))$ is identical to (x_n, y_n) , because we can solve the equation for an ellipse in terms of y to get a function, $f(x_n)$ to find the y-value at the x-value of x_n .

Next, we will do some manipulation to our equation for an ellipse, to get it in the forms that we need for our algorithm.

The basic equation for an ellipse is $\frac{x^2}{a^2} + \frac{y^2}{b^2} = 1$, but in our case, a is the radius of the parachute and b is the height, so we will use the equation $\frac{x^2}{r^2} + \frac{y^2}{h^2} = 1$ instead.

Solving for y yields: $f(x) = y = h\sqrt{1 - \frac{x^2}{r^2}}$ (Actually the left side should have a \pm sign, but we do not include it, because we are only concerned with the positive side of the ellipse)

And next, we take the derivative using implicit differentiation:

$$\begin{aligned} \frac{x^2}{r^2} + \frac{y^2}{h^2} &= 1 \\ \left(\frac{1}{r^2}\right)x^2 + \left(\frac{1}{h^2}\right)y^2 &= 1 && \text{(Note}^3\text{)} \\ \frac{d}{dx} \left[\left(\frac{1}{r^2}\right)x^2 + \left(\frac{1}{h^2}\right)y^2 \right] &= \frac{d}{dx}[1] && \text{Implicit Differentiation} \\ \left(\frac{1}{r^2}\right)2x + \left(\frac{1}{h^2}\right)2y \left(\frac{dy}{dx}\right) &= 0 \\ \frac{2y \left(\frac{dy}{dx}\right)}{b^2} &= -\frac{2x}{r^2} \\ \frac{dy}{dx} &= -\frac{h^2x}{r^2y} \\ \frac{dy}{dx} &= -\frac{h^2x}{r^2h\sqrt{1-\frac{x^2}{r^2}}} && \text{Substitute for } y \\ f'(x) = \frac{dy}{dx} &= -\frac{hx}{r^2\sqrt{1-\frac{x^2}{r^2}}} \end{aligned}$$

We could simplify the derivative further by rationalizing the denominator, but the current formula is faster when calculated on a computer, so we will leave it here.

Next, given any point $(x_n, f(x_n))$, we will calculate the point $(x_{n+1}, f(x_{n+1}))$, which is z cm away from $(x_n, f(x_n))$.

Here is the only flaw in algorithm, which is why it is only an approximation of the ellipse: We assume that the ellipse is a straight line passing through the two points, and thus, $f'(x_n) = f'(x_{n+1})$. This is obviously not true, because an ellipse does not consist of straight lines, but since any two adjacent points are

³ $\left(\frac{1}{r^2}\right)$ and $\left(\frac{1}{h^2}\right)$ are treated as constants for the parachute

extremely close together, we can make this assumption without causing too much error in the results. (We will actually calculate this error later, just to make sure)

$$\begin{aligned}
 f'(x_n) &= \frac{\Delta y}{\Delta x} && \text{Assumption} \\
 \Delta x^2 + \Delta y^2 &= z^2 && \text{Pythagorean Theorem} \\
 \Delta y &= \sqrt{z^2 - \Delta x^2} \\
 f'(x_n) &= \frac{\sqrt{z^2 - \Delta x^2}}{\Delta x} && \text{Substitution} \\
 \Delta x \cdot f'(x_n) &= \sqrt{z^2 - \Delta x^2} \\
 (\Delta x \cdot f'(x_n))^2 &= z^2 - \Delta x^2 \\
 \Delta x^2 (f'(x)^2 + 1) &= z^2 \\
 \Delta x^2 &= \frac{z^2}{f'(x)^2 + 1} \\
 \Delta x &= \frac{z}{\sqrt{f'(x)^2 + 1}}
 \end{aligned}$$

We substitute our $f'(x)$ from the section above:

$$\Delta x = \frac{z}{\sqrt{\left[\frac{h \cdot x_n}{r^2 \sqrt{1 - \frac{(x_n)^2}{r^2}}} \right]^2 + 1}}$$

Since $x_{n+1} = x_n - \Delta x$, substitution yields:

$$x_{n+1} = x_n - \frac{z}{\sqrt{\left[\frac{hx}{r^2 \sqrt{1 - \frac{(x_n)^2}{r^2}}} \right]^2 + 1}}$$

And now we have our recursive formula for finding an adjacent point on the ellipse!

Now let's put out recursive formula to use. But first, more notation: p_n denotes the n^{th} point on the vertical cross-section, while P_n denotes the n^{th} point on the panel. Mathematically, this could be written as $p_n = (x_n, y_n)$ and $P_n = (X_n, Y_n)$. Since we are calculating more points than we are actually going to use, we also need a way to denote the calculated points. These we will call c_n .

Mapping calculated points (c_n 's) to vertical cross-section points (p_n 's) is fairly easy. The first calculated point maps to the first vertical cross-section point ($c_1 = p_1$). Then, we ignore the next few points, as determined by the precision. For instance, if precision (F) was 10, then we are calculating 10 points for every one that are used, thus points c_2 through c_{10} are dropped, and the next point we use is c_{11} , which would map to p_2 . The mathematical formula for this is:

$$p_n = c_{F(n-1)+1}$$

(Note the similarity to the formula for the number of calculated points, c)

We know the first and last points on our ellipse, p_1 and p_p (which map to c_1 and c_c):

$$p_1 = c_1 = (r, 0)$$

$$p_p = c_c = (0, h)$$

Now that we have $c_1 = (r, 0)$, giving us $x_1 = r$, we can calculate all of the points in between c_1 and c_c using our recursive formula⁴.

⁴Our recursive formula only gives us x-values, but we could calculate the y-values using our formula, $f(x)$, which is the equation for an ellipse solved in terms of y . As you will see later, we do not need to do this, because we only use the x-values of the coordinates.

Since we have calculated a value for the second-to-last point $(c_c - 1)$, we might as well give our recursive formula one more run, and calculate c_c again, even though we know its value. We do this to establish how far off our estimates are, by calculating a percent error value. If the percent error is high, this would indicate that we should increase our precision factor and run the program all over again. Heres the formula for percent error:

$$\%_{\text{error}} = \frac{|x_c - r|}{r} \cdot 100$$

We have calculated our points and pulled out only the ones we will use, so next we must convert our vertical cross-section points to actual points on the parachute panel. As stated before, we do this by taking the horizontal cross-section through the point on the parachute, which is a circle, which happens to have the same radius as a x-value in p_n . The formulas should be simple enough to prove on your own, so here they are:

$$X_n = \pm \frac{2\pi x_n}{P_n}$$

$$Y_n = \frac{P_l(n - 1)}{p - 1}$$

We now can calculate the coordinates for the curved part of the panel for any elliptical parachute! Although that's the meat of the section, there are still some more calculations left, to take full advantage of the parachute algorithm. The overhang formulas look fairly complicated, but they can be derived using basic geometry, so their proofs will not be included here.

Variable	Description	Unit	Formula
P_w	Max. Panel Width	cm	$P_w = 2X_1$
O_r	Overhang Radius	cm	$O_r = \frac{P_w^2}{4o} + o$
O_a	Overhang Angle	rad.	$O_a = 2 \arcsin\left(\frac{P_w}{2O_r}\right)$
O_v	Overhang Vertex	(x, y)	$O_v = (0, O_r - o)$
A_{overhang}	Overhang Area	cm ²	$= \frac{(O_a \cdot O_r^2) - (P_w[O_r - o])}{2}$
A_{opening}	Opening Area	cm ²	$A_{\text{opening}} = \pi r^2$
V_{inner}	Inner Volume	cm ³	$V_{\text{inner}} = \frac{2\pi}{3} \cdot hr^2$
A_{panel}	Panel Area	cm ²	$A_{\text{panel}} = \sum_{n=2}^p (X_n + X_{n-1}) \left(\frac{P_l}{p-1}\right)$
A_{surface}	Surface Area	cm ²	$A_{\text{surface}} = A_{\text{panel}} \cdot P_n$
S_l	Seam Length	cm	$= \sum_{n=2}^p \sqrt{(x_n - x_{n-1})^2 + (y_n - y_{n-1})^2}$
A_{seam}	Seam Area	cm ²	$A_{\text{seam}} = S_l s$
A_{total}	Total Area	cm ²	$= (A_{\text{panel}} + A_{\text{overhang}} + 2A_{\text{seam}}) \cdot P_n$
V_{folded}	Volume Folded	cm ³	$V_{\text{folded}} = A_{\text{total}} \cdot M_t$
m	Mass	g	$m = V_{\text{folded}} \cdot M_d$

12.2 Angle Repetition Algorithm

The Angle Repetition Algorithm is another algorithm for calculating equidistant points on an ellipse. It requires a significantly greater amount of processing time, and it is not as accurate, but it can be done without using calculus.

The algorithm works similar to the Tangent Points Algorithm, but instead of using derivatives to calculate points, it uses a ray, drawn from the center of the ellipse. First, the approximate point distance is calculated. Then, the slope of the ray is gradually increased, until the point of intersection of the ray and the ellipse is the correct distance from the previous point.

Chapter 13

Simulators

Simulators are the most useful tools for designing rockets. Algorithms for stability and parachutes were discussed in previous chapters, so this chapter will look at simulating the flight of the rocket to predict factors such as flight time, height, and acceleration.

Simulators give only an estimation of a flight. The actual height, time aloft, and other characteristics can vary tremendously from the simulated values, sometimes by 50% or more. Although outside factors make the actual flight unpredictable, this is what makes simulators so important. Because there are so many uncontrollable factors, simulators are often the only method of comparing modifications to rockets. (For example: Which rocket stays aloft longer, a 150 g rocket with an 80 cm parachute, or a 200 g rocket with a 100 cm parachute?) To answer this question without a simulator, you would have to build two different rockets, two different parachutes, and measure the time aloft on numerous launches of each to get accurate enough averages to determine the answer. Not only does this take days to do, but it is often impossible, because rockets often have a short lifespan of only a few launches. As soon as one of the two rockets fails, and crashes to the ground, you have to build a new rocket and start testing all over again. Simulators make this task

much easier—simply punch in a few numbers, and the simulator will compare the two rockets.

13.1 Notation

Because of the number of different constants, variables, and functions used in the bottle rocket simulator, notation becomes very difficult. For the purpose of clarity, the following naming conventions are used throughout this chapter:

a denotes acceleration	A denotes Area
d denotes diameter	D denotes Density
m denotes mass in kg	M denotes Molar Mass (kg/mol)
t denotes time	T denotes Temperature
v denotes velocity	V denotes Volume

In addition, standard units of measure are used for variables, constants, and functions. This may look awkward when doing computations (For instance, the diameter of the nozzle will be measured in, yes, *meters!*), but it makes the rest of the formulas far less complicated. The following units of measure are assumed for *all* values:

Acceleration	m/s ²
Area	m ²
Density	kg/m ³
Force	newtons
Length (Height, Diameter, etc.)	meters
Mass	kilograms
Molar Mass	kg/mol
Pressure	Pascals
Temperature	Kelvin
Time	seconds
Velocity	m/s
Volume	m ³

Finally, we must make a distinction between the air on the inside and outside of the bottle, because they have different pressures

and densities, which is important in our calculations. The air inside the bottle will be referred to as *air*, while the air on the outside will be referred to as *atmosphere*.

13.2 Constants, Variables, and Functions

It is important to understand how constants, variables, and functions are used in this simulator.

A constant (such as π) is a number that *never* changes. Constants are used to determine the relationship between different units and measurements, such as the ideal gas constant, K_{gas} , which relates the pressure, volume, and temperature of a gas.

A variable (such as diameter) is a number that changes with the rocket. The value of a variable can be different for each rocket, but the value of the variable stays the same throughout the entire flight of a rocket.

Functions (such as velocity) are used for values that are constantly changing throughout the flight of a rocket. These values are written as a function of time, t , ($f(t)$). The variable t represents the time, in seconds, since the rocket is launched (when the locking mechanism is released, not when it comes off the launch pad).

13.3 Acceleration, Velocity, and Height

Acceleration, velocity, and height are the three most important functions in the simulator and are written as $a(t)$, $v(t)$, and $h(t)$, respectively. Determining the values of these three functions is the purpose of a simulator. The graphs of these functions are often plotted, to determine information such as maximum height, maximum acceleration, impact velocity, time of apogee, and time aloft.

These three functions are related by integration. Integrating $a(t)$ yields $v(t)$, and integrating $v(t)$ yields $h(t)$. Thus, if we can

calculate the value of one function, we can determine the values of the other two.

We will determine the value of the acceleration function, $a(t)$, using Newton's law,

$$\text{Force} = \text{Mass} \times \text{Acceleration}$$

By rearranging to get the acceleration function by itself, we get:

$$a(t) = \frac{F_{\text{sum}}(t)}{m(t)}$$

$F_{\text{sum}}(t)$ is the sum of the different forces that act upon the rocket. We can calculate it by adding together all the different forces that our simulator takes into consideration:

$$F_{\text{sum}}(t) = F_{\text{grav}}(t) + F_{\text{rod}}(t) + F_{\text{drag}}(t) + F_{\text{prop}}(t) + F_{\text{par}}(t)$$

$m(t)$ is the function for the total mass of the rocket (including water) at any given time. We will calculate this function in a later section.

13.4 Computer Integration

The acceleration formula has not gotten extremely complex yet, but over the next ten pages, it will. Obviously, we don't want to do all of this calculus by hand, so now is a good time to explain how to integrate a formula like this one using a computer.

To integrate a complex function, like the acceleration function presented in this chapter, the best we can do is to find an approximation of the integral—the formula is far too complex to get an exact value. We can approximate this estimate using the rectangle method¹.

¹A better approximation formula for integrals, such as the Trapezoidal Rule or Simpson's Rule, can be used for a more efficient simulator

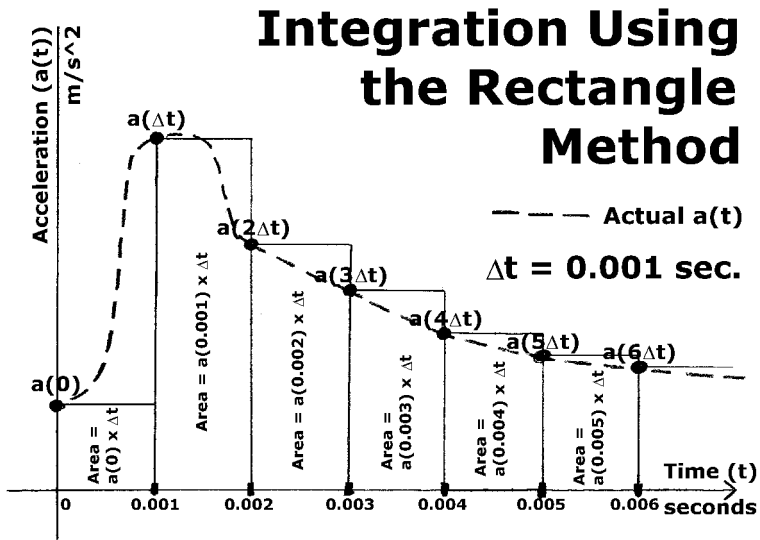

Figure 13.1: Integration Using the Rectangle Method

Instead of letting Δt equal zero and finding the limit, like we would do if we were finding an exact value, we set it to a value extremely close to zero, like 0.001. (Remember, Δt is a measure of time, thus its unit of measure is seconds. 0.001 seconds equals one millisecond.)

We start off with $t = 0$, and compute our value of $a(t)$. We will next recalculate $a(t)$ at $t = \Delta t$, so we will assume that the value of $a(t)$ stays the same from 0 to Δt . If we plot these values on a graph, and draw a rectangle extending to the x-axis, we have a rectangle of area:

$$A(0) = a(0) \cdot \Delta t$$

We increment our time, t , by Δt and repeat this process. The sum of all of these rectangles should make a close approximation of the integral of $a(t)$:

$$\int_0^{t_{\text{impact}}} a(t) dt \approx \sum_{t=0}^{(t_{\text{impact}}/\Delta t)} (a(t \cdot \Delta t) \cdot \Delta t)$$

Notice that we integrate from 0 to t_{impact} . Where did t_{impact} come from? When we begin our simulation, we have no clue how long the rocket's flight time will last. t_{impact} is not a real value—it just tells us to start calculating values, and integrate until $h(t)$ hits the ground.

We can integrate $v(t)$ the same way to get $h(t)$:

$$\int_0^{t_{\text{impact}}} v(t) dt \approx \sum_{t=0}^{(t_{\text{impact}}/\Delta t)} (v(t \cdot \Delta t) \cdot \Delta t)$$

You will also notice that some of the formulas in this section require the value from a function that we cannot calculate, until we calculate the first formula (e.g. $v(t)$ and $F_{\text{drag}}(t)$). This is another benefit of integration on a computer—we can simply use the last calculated value of the function (usually $f(t - \Delta t)$) as an approximation of the actual value that we need.

13.5 Calculations

13.5.1 Launch Rod

Although the launch rod may seem to be of little importance, it is actually critical to a simulator and to the flight of a rocket. Even on launchers with only small rubber fitting as a launch

rod (usually with a length of 2 cm or less), the rocket will reach a speed of 10 MPH before it ever leaves the launch rod. On launchers that use a pipe or other longer launch rod, this speed is greater, and the launch rod is even more critical.

The following are input values related to the launch rod:

Variable	Description	Unit
d_{rod}	Diameter of Launch Rod ²	m
l_{rod}	Length of Launch Rod	m

Since we will need the area of the top of the launch rod for further calculations, we will first find the radius of the launch rod, r_{rod} , and then calculate the perpendicular surface area of the launch rod, A_{rod} :

$$r_{\text{rod}} = \frac{d_{\text{rod}}}{2}$$

$$A_{\text{rod}} = \pi(r_{\text{rod}})^2$$

We will also do the same for R_{nozzle} and A_{nozzle} :

$$r_{\text{nozzle}} = \frac{d_{\text{nozzle}}}{2}$$

$$A_{\text{nozzle}} = \pi(r_{\text{nozzle}})^2$$

As the rocket goes up as it is coming off the launch pad, the amount of the launch rod inside the bottle decreases. Next, we will calculate two functions, $l_{\text{rodB}}(t)$ and $V_{\text{rodB}}(t)$, to determine the length and volume of the launch rod remaining inside the bottle:

$$l_{\text{rodB}}(t) = l_{\text{rod}} - h(t)$$

$$V_{\text{rodB}}(t) = l_{\text{rodB}}(t) \cdot A_{\text{rod}}$$

²The diameter of the launch rod must be the same as the nozzle of the bottle, therefore the value of d_{rod} may be referred to as d_{nozzle} when it is used to calculate water flow out of the nozzle.

13.5.2 Pressurized Bottle, Water, and Air

There are three things inside the pressurized bottle during the initial launch: water, launch rod, and air. Now that we have calculated the volume of launch rod, we must calculate the water and air.

The following variables are inputs for our simulator:

Variable	Description	Unit
V	Bottle Volume	m^3
d	Bottle Diameter	m
$V_{\text{water}}(0)$	Initial Water Volume	m^3
$P_{\text{air}}(0)$	Initial Air Pressure	Pa
C_d	Drag Coefficient of Rocket	C_d

$V_{\text{water}}(0)$ is the initial value of the function $V_{\text{water}}(t)$. We will show how to calculate $V_{\text{water}}(t)$ for values of t other than zero in the section, *Propulsive Forces*.

We now have the volume of water and launch rod inside the bottle, therefore the rest must be air. Let $V_{\text{air}}(t)$ represent the volume of air inside the bottle (in m^3):

$$V_{\text{air}}(t) = V - V_{\text{water}}(t) - V_{\text{rodB}}(t)$$

Boyle's Law states that the pressure and volume of a gas vary inversely. Thus, as the volume of air inside the bottle increases, due to the water and launch rod leaving, the pressure of the air decreases proportionally. Using Boyle's Law, $P_1V_1 = P_2V_2$, we get the formula for the air pressure inside the bottle, $P_{\text{air}}(t)$:

$$P_{\text{air}}(t) = \frac{P_{\text{air}}(0) \cdot V_{\text{air}}(0)}{V_{\text{air}}(t)}$$

13.5.3 Preliminary Propulsive Calculations

The next step involves calculating the height of the water inside the bottle and the surface area of the top of the water. We need these values to calculate the propulsion of water out of the bottle.

This is one place we will make a large simplification. We could actually measure the diameter of the bottle at many different heights to input the bottle's shape into the simulator, but instead, we will simply assume that the bottle is a perfect cylinder, with a hole the size of the nozzle in the bottom. For 2-liter bottles, this simplification should not make much of a difference. For bottles with a longer neck, this may make more of a difference. Also, by working it out the long way, and measuring actual diameters, we could make a simulator that compares the propulsion of different shapes of bottles. This will not be covered here.

For our cylindrical bottle, the perpendicular area of the bottle, A_{perp} , can be found using the formula:

$$A_{\text{perp}} = \pi r^2$$

We also have a function, $A_{\text{surf}}(t)$, which is the surface area of the top of the volume of water indicated by $V_{\text{water}}(t)$. For our cylindrical bottle, this value will always be the same as the perpendicular area of our bottle:

$$A_{\text{surf}}(t) = A_{\text{perp}}$$

Finally, we must find the height of the water level, $h_{\text{water}}(t)$. For our cylindrical bottle, this is easy:

$$h_{\text{bottle}} = \frac{V_{\text{water}}(t)}{A_{\text{surf}}(t)}$$

13.5.4 Mass

Mass is another important factor in rocket design. A simulator must also consider the changing mass of the rocket, due to the propulsion of the water.

Our simulator will have three more input variables:

Variable	Description	Standard Value	Unit
m_{empty}	Empty Mass		kg
D_{water}	Density of Water	1000	kg/m ³
a_{grav}	Acceleration of Gravity	-9.806	m/s ²

D_{water} is typically 1000 kg/m³, but by using a variable, we can test the effect of different substances as propellants. a_{grav} is similar—here on Earth, the value does not change, but just in case you wanted to see what a rocket would do under the moon’s gravity...

To calculate the changing mass, we first find the mass of water, $m_{\text{water}}(t)$:

$$m_{\text{water}}(t) = V_{\text{water}}(t) \cdot D_{\text{water}}$$

We simply add the empty mass of the rocket to mass of the water to get the total mass, $m(t)$:

$$m(t) = m + m_{\text{water}}(t)$$

13.5.5 Air and Atmosphere

The next thing our simulator will need is the density of air and atmosphere. (Remember the difference: *air* is inside the rocket; *atmosphere* is outside.)

Calculating the density of air and atmosphere will require five more inputs:

Variable	Description	Standard Value	Unit
v_{updraft}	Updraft Velocity	0	m/s
P_{atm}	Atmospheric Pressure	101325	Pa
T_{atm}	Atmospheric Temperature		K
T_{air}	Air Temperature		K
M_{atm}	Molar Mass of Atmosphere	0.029	kg/mol
M_{air}	Molar Mass of Air	0.029	kg/mol

Updraft velocity is a constant, that in later calculations, will be added to the rocket's velocity to determine the relative wind. A positive value will simulate an updraft resulting from a thermal or a hill. Typical updrafts range from 0 to 0.5 m/s.

Notice that the air temperature and atmosphere temperature are input as separate values. Shouldn't they be the same since the air we pump inside comes directly from the air outside? Not exactly. On most launchers, the air comes out of the launch rod and bubbles up through the water. When this occurs, there is a heat exchange between the air and the water. The change in temperature is small, so it has little effect on the overall launch, but this gives you the option of experimenting with heated or chilled air inside the rocket.

Another important thing to notice is that the molar mass of air is input separately from atmosphere. The typical value for the air we breath is 0.029 kg/mol, but many bottle rocket launchers are equipped with air tanks, and often, nitrogen, oxygen, or another gas is used instead of ordinary air. The type of gas used to pressurize the rocket *does* make a difference, so here are some values of common gases:

Gas	Molar Mass
Helium (He)	0.004 kg/mol
Nitrogen (N ₂)	0.028 kg/mol
Air	0.029 kg/mol
Oxygen (O ₂)	0.032 kg/mol
Carbon Dioxide (CO ₂)	0.044 kg/mol

We will make another assumption: air, or whatever other gas we are using, is an ideal gas. This allows us to use the Ideal Gas Law,

$$PV = nRT$$

where P represents pressure, V represents volume, n represents the number of moles of gas, R is a gas constant, and T is the temperature in Kelvin. Since:

$$\begin{aligned} \text{Number of Moles} &= \frac{\text{Mass}}{\text{Molar Mass}} \\ n &= \frac{m}{M} \end{aligned}$$

we can rewrite the equation as

$$\begin{aligned} PV &= \frac{mRT}{M} \\ MPV &= mRT \\ \frac{PM}{RT} &= \frac{m}{V} \end{aligned}$$

Since:

$$\begin{aligned} \frac{\text{Mass}}{\text{Volume}} &= \text{Density} \\ \frac{m}{V} &= D \end{aligned}$$

we can substitute m/V for D , yielding:

$$D = \frac{P \cdot M}{R \cdot T}$$

With this variation of the Ideal Gas Law, we get the following two equations for the density of air, D_{air} , and the density of atmosphere, D_{atm} :

$$\begin{aligned} D_{\text{air}} &= \frac{P_{\text{air}} \cdot M_{\text{air}}}{K_{\text{gas}} \cdot T_{\text{air}}} \\ D_{\text{atm}} &= \frac{P_{\text{atm}} \cdot M_{\text{atm}}}{K_{\text{gas}} \cdot T_{\text{atm}}} \end{aligned}$$

$$(K_{\text{gas}} \approx 8.31441 \text{ Pa} \cdot \text{m}^3/\text{mol} \cdot \text{K})$$

13.5.6 Parachute

The final set of calculations involves parachutes. The following values are needed as inputs:

Variable	Description	Unit
n_{par}	Number of Parachutes	
A_{par}	Surface Area of Each Parachute	m^2
C_{pd}	Parachute Drag Coefficient	C_d
T_{deploy}	Length of Time to Fully Deploy	sec.
K_{par}	Parachute Deploy Constant	

All of the values should be self-explanatory, except for one: the parachute deploy constant, K_{par} . This is a value used to deploy the parachute exponentially. Without an exponential deploy, the parachute instantly being fully deployed would cause a huge jump in the acceleration graph, causing G-forces that would rip the rocket apart. A value of 10 is normally used for K_{par} . This value has no logical meaning and little scientific basis, but it seems to work well. Lower values create a smoother deploy, while higher values will create a rougher one.

To calculate our parachute's deploy, we need to keep track of our apogee time, which we will record as t_{apogee} . So how do we know when the rocket is at apogee? The First Derivative Test! Whenever our $v(t)$ value goes from positive to negative, our rocket has passed apogee. At this time, we store the current value of the elapsed time, t , as t_{apogee} .

After apogee, we can start calculating the percent deployed of our parachute, $\%_{\text{deployed}}(t)$:

$$\%_{\text{deployed}}(t) = \left(\frac{t - t_{\text{apogee}}}{t_{\text{deploy}}} \right)^{K_{\text{par}}} \times 100$$

Like K_{par} , our formula for $\%_{\text{deployed}}(t)$ just generates an arbitrary $y = x^k$ graph that seems to make a smooth parachute deploy.

From $\%_{\text{deployed}}(t)$, we calculate the total area of parachute that has been deployed, $A_{\text{parD}}(t)$:

$$A_{\text{parD}}(t) = n_{\text{par}} \cdot A_{\text{par}} \cdot \%_{\text{deployed}}(t)$$

13.6 Forces

13.6.1 Gravity

With all of our overhead calculations completed, we can begin calculating the actual forces that act on the rocket. First, we will look at gravity.

Remember the $F = ma$ equation from the beginning of the chapter? We will use this same equation to calculate the force of gravity:

$$F_{\text{grav}}(t) = m(t) \cdot a_{\text{grav}}$$

13.6.2 Launch Rod Reaction Force

The launch rod reaction force is the force that gives the rocket its initial “push” off the launch pad. It is actually two forces in one: the force of the air inside the bottle pushing on the launch rod minus the force of the atmosphere which is working against the launch rod reaction force.

We can calculate these forces by taking the pressure inside the bottle and multiplying it times the area of the surface which it pushes against:

$$\begin{aligned} F_{\text{air}}(t) &= P_{\text{air}}(t) \cdot A_{\text{rod}} \\ F_{\text{atm}}(t) &= P_{\text{atm}} \cdot A_{\text{rod}} \end{aligned}$$

Subtracting these forces yields:

$$\begin{aligned} F_{\text{rod}}(t) &= F_{\text{air}}(t) - F_{\text{atm}}(t) \\ F_{\text{rod}}(t) &= (P_{\text{air}}(t) \cdot A_{\text{rod}}) - (P_{\text{atm}} \cdot A_{\text{rod}}) \\ F_{\text{rod}}(t) &= A_{\text{rod}}(P_{\text{air}}(t) - P_{\text{atm}}) \end{aligned}$$

13.6.3 Wind Resistance

Since there is no exact formula to calculate the wind resistance of an object moving through the air, scientists approximate this force using a drag coefficient, or C_d . The only accurate way to determine a drag coefficient is by experimentation in a wind tunnel, but drag coefficients for bottle rockets are typically in the 0.2 to 0.5 range. Here is the formula for the wind resistance of the rocket:

$$F_{\text{drag}}(t) = \pm \frac{C_d \cdot D_{\text{atm}} \cdot A_{\text{perp}} \cdot [v(t) + v_{\text{updraft}}]^2}{2}$$

Wind resistance is typically a downward force, but you must look at the velocity of the relative wind, $v(t) + v_{\text{updraft}}$, to determine whether the force is truly positive or negative.

13.6.4 Propulsive Forces

The propulsive force of the rocket is caused by the water that pushed through the nozzle by the pressurized air. Remember the law, “For every action, there is an equal and opposite reaction?” In this case, the action is pushing water out of the nozzle, and the reaction is the propulsive force that makes the rocket go up.

First, we must realize that the water at the water’s surface is moving at a different velocity than the water at the nozzle. Second, we must show that at any point in the water, there is an inverse relationship between the velocity of the water and the area of the bottle’s horizontal cross-section.

Let’s assume that at a given point in time, the velocity of the surface of the water is $v_{\text{surf}}(t)$ meters per second. Therefore, in a period of time, Δt , the water level will drop h_{surf} meters, where

$$\begin{aligned} h_{\text{surf}} &= v_{\text{surf}}(t) \cdot \Delta t \\ (\text{Distance}) &= \text{Rate} \times \text{Time} \end{aligned}$$

Thus, the volume of water that left the rocket, V_{surf} , is:

$$V_{\text{surf}} = h_{\text{surf}} \cdot A_{\text{surf}}(t)$$

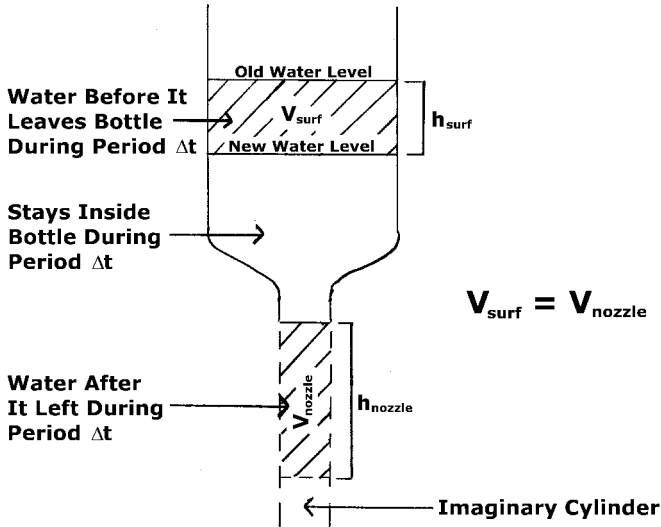

Figure 13.2: Proving there is an inverse relationship between the velocity and area of the moving water

Since this water had to go somewhere, it must have gone out of the nozzle, therefore there is now a volume of water, V_{nozzle} , that has come out of the nozzle. Assuming this water did not spray out, but stayed packed into a cylinder with the same diameter as the nozzle, this cylinder would have a height, h_{nozzle} , of:

$$h_{nozzle} = \frac{V_{nozzle}}{A_{nozzle}}$$

Since h_{nozzle} meters of water have come out in Δt seconds, working backwards from Distance = Rate \times Time gives us:

$$v_{nozzle}(t) = \frac{h_{nozzle}}{\Delta t}$$

Since we must have the same amount of water at the beginning of the period Δt as we have at the end,

$$V_{surf} = V_{nozzle}$$

Substitution yields:

$$\begin{aligned} h_{\text{surf}} \cdot A_{\text{surf}}(t) &= h_{\text{nozzle}} \cdot A_{\text{nozzle}} \\ v_{\text{surf}}(t) \cdot \Delta t \cdot A_{\text{surf}}(t) &= v_{\text{nozzle}}(t) \cdot \Delta t \cdot A_{\text{nozzle}} \end{aligned}$$

Cancelling out Δt from each side yields:

$$v_{\text{surf}}(t) \cdot A_{\text{surf}}(t) = v_{\text{nozzle}}(t) \cdot A_{\text{nozzle}}$$

Therefore, we have an inverse relationship between the velocity and area of the moving water.

$v_{\text{nozzle}}(t)$ is the function which we are looking for. We will solve the equation in terms of $v_{\text{surf}}(t)$ so we can substitute later and get rid of the $v_{\text{surf}}(t)$ term:

$$v_{\text{surf}}(t) = \frac{v_{\text{nozzle}}(t) \cdot A_{\text{nozzle}}}{A_{\text{surf}}(t)}$$

Now, we are ready to calculate the velocity of the water leaving the rocket. We calculate this using Bernoulli's Law, which says that at any point along the flow of water,

$$p + d \cdot g \cdot h + \frac{1}{2} \cdot d \cdot v^2$$

equals a constant. p represents pressure, d represents water density, h represents height, and v represents the velocity of water. The first term accounts for the air pressure pushing against the water; the second accounts for the increased water pressure at the bottom due to gravity; and the third term accounts for the velocity of the moving water.

Using Bernoulli's Law for the surface of the water gives us:

$$[P_{\text{air}}(t) - P_{\text{atm}}] + D_{\text{water}} \cdot [a_{\text{grav}} - a(t)] \cdot h_{\text{water}}(t) + \frac{1}{2} \cdot D_{\text{water}} \cdot [v_{\text{surf}}(t)]^2 = \text{const}$$

First, notice the first term subtracts the atmospheric pressure from the air pressure. This is because the force of the atmospheric

pressure cancels out part of the force of the air pressure. For instance, if the air inside was at a pressure of 15 PSI and the air outside was also at 15 PSI, no propulsion would result.

Second, notice that the g , which represented the acceleration of gravity, has been replaced by $[a_{\text{grav}} - a(t)]$. This is because the rocket is accelerating, so we must account for the added acceleration, $a(t)$. $a(t)$ is subtracted to make this value negative, because of the “equal and opposite reaction” law—since the rocket accelerates upward, this creates a force which pushes the water downward.

Using Bernoulli’s Law for the water in the nozzle gives us:

$$\frac{1}{2} \cdot D_{\text{water}} \cdot [v_{\text{nozzle}}(t)]^2 = \text{const}$$

Notice that the first term disappears because there is no pressure acting on the nozzle (We took care of the atmospheric pressure when we subtracted it in the previous equation.). The second term disappears, because height is relative to the bottom, therefore the height for this equation is zero.

Since the constants must be equal, we can set these two equations equal to each other:

$$[P_{\text{air}}(t) - P_{\text{atm}}] + D_{\text{water}} \cdot [a_{\text{grav}} - a(t)] \cdot h_{\text{water}}(t) + \frac{1}{2} \cdot D_{\text{water}} \cdot [v_{\text{surf}}(t)]^2 = \frac{1}{2} \cdot D_{\text{water}} \cdot [v_{\text{nozzle}}(t)]^2$$

Rearranging yields:

$$\begin{aligned} \frac{1}{2} \cdot D_{\text{water}} \cdot [v_{\text{nozzle}}(t)]^2 - \frac{1}{2} \cdot D_{\text{water}} \cdot [v_{\text{surf}}(t)]^2 &= \\ &= P_{\text{air}}(t) - P_{\text{atm}} + D_{\text{water}} \cdot [a_{\text{grav}} - a(t)] \cdot h_{\text{water}}(t) \end{aligned}$$

$$\begin{aligned} \left(\frac{D_{\text{water}}}{2} \right) \left([v_{\text{nozzle}}(t)]^2 - [v_{\text{surf}}(t)]^2 \right) &= \\ &= P_{\text{air}}(t) - P_{\text{atm}} + D_{\text{water}} \cdot [a_{\text{grav}} - a(t)] \cdot h_{\text{water}}(t) \end{aligned}$$

Substituting for v_{surf} gives us:

$$\begin{aligned} \left(\frac{D_{\text{water}}}{2}\right) \left([v_{\text{nozzle}}(t)]^2 - \frac{[A_{\text{nozzle}}(t)]^2 \cdot [V_{\text{nozzle}}(t)]^2}{[A_{\text{surf}}(t)]^2} \right) &= \\ &= P_{\text{air}}(t) - P_{\text{atm}} + D_{\text{water}} \cdot [a_{\text{grav}} - a(t)] \cdot h_{\text{water}}(t) \end{aligned}$$

Factoring out $[v_{\text{nozzle}}(t)]^2$:

$$\begin{aligned} [v_{\text{nozzle}}(t)]^2 \left(\frac{D_{\text{water}}}{2}\right) \left(1 - \left(\frac{A_{\text{nozzle}}}{A_{\text{surf}}}\right)^2 \right) &= \\ &= P_{\text{air}}(t) - P_{\text{atm}} + D_{\text{water}} \cdot [a_{\text{grav}} - a(t)] \cdot h_{\text{water}}(t) \end{aligned}$$

Solving for $v_{\text{nozzle}}(t)$:

$$v_{\text{nozzle}}(t) = \sqrt{\frac{2 [P_{\text{air}}(t) - P_{\text{atm}} + D_{\text{water}} \cdot [a_{\text{grav}} - a(t)] \cdot h_{\text{water}}(t)]}{D_{\text{water}} \cdot \left(1 - \left(\frac{A_{\text{nozzle}}}{A_{\text{surf}}}\right)^2 \right)}}$$

Unfortunately, we're not done yet. We have only calculated the *velocity* of the water being expelled through the nozzle. We have not yet calculated the volume during the time period Δt , or the resulting force from expelling the water.

Calculating volume is easy. (Anything is easy after calculating the velocity!) We simply assume the water fits into a cylinder the size of the nozzle. Using Distance = Rate \times Time, we get that the height of water, $h_{\text{expelled}}(t)$, expelled during Δt is:

$$H_{\text{expelled}}(t) = v_{\text{nozzle}}(t) \cdot \Delta t$$

Once we have the height of the cylinder, we calculate volume by multiplying the height by the surface area of the base:

$$V_{\text{expelled}}(t) = h_{\text{expelled}}(t) \cdot A_{\text{nozzle}}$$

Next, we convert volume of water into mass:

$$m_{\text{expelled}}(t) = V_{\text{expelled}}(t) \cdot D_{\text{water}}$$

Finally, we calculate the resulting propulsive force ($F_{\text{prop}}(t)$) created by expelling $m_{\text{expelled}}(t)$ kilograms of water at a rate of $v_{\text{nozzle}}(t)$ meters per second:

$$F_{\text{prop}}(t) = m_{\text{expelled}}(t) \cdot v_{\text{nozzle}}(t) \cdot \Delta t$$

13.6.5 Air Pulse

In addition to propulsion resulting from the expulsion of water, there is also another type of propulsion that the simulator does not consider: the release of the remaining air pressure after the water is gone. The “air pulse,” as it is called, adds a small amount of thrust to any rocket launch—a rocket with no water will even go 10 to 15 feet in the air. An instantaneous acceleration could be added to the thrust for the time period, Δt , that this air pulse occurs. Another possibility to explore is the derivation of an actual formula to calculate the thrust resulting from the air pulse. Although we will not go into it here, more information on the air pulse is available on the Internet.

13.6.6 Parachute Drag

Parachute drag is calculated in the same manner as rocket drag, except it is typically in the opposite direction:

$$F_{\text{par}}(t) = \pm \frac{C_{pd} \cdot D_{\text{atm}} \cdot A_{\text{parD}}(t) \cdot [v(t) + v_{\text{updraft}}]^2}{2}$$

Like rocket drag, you must look at $v(t) + v_{\text{updraft}}$ to determine whether this is a positive or negative force.

13.7 Conclusion

Simulators are a great tool for developing rockets, because they allow you to test modifications in seconds, without spending the days required to do actual testing. The simulator covers some of the most important forces, but it does not cover every one. There are still many more factors that could be taken into consideration by a simulator, such as wind, air pulse, fin drag, stability, and bottle shape.

Appendix A

Water Markings

Since simulators can tell us the optimized water level for a particular rocket, we need a way to accurately measure the water in the bottle. The diagram below shows the standard water markings used on the pressurized bottle:

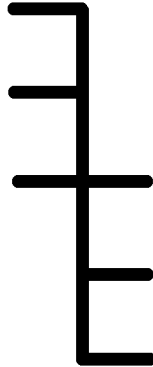

Figure A.1: Standard Water Markings

Notice that the markings have diagonal symmetry—when the bottle is turned upside down, the markings stay the same. This is important, because sometimes water is measured when the bottle is right-side-up (while putting the rocket on the launcher); other

times it is measured upside-down (while filling with water). This allows you to use the same water markings, no matter what type of launch set-up is used.

Since the markings are symmetrical, only one set is used at a time. The side on the right (which is always at the bottom) is the side that you will use. The lowest line represents the 30% water level for the bottle. Above it is the 40% water level. The top line (the longest one) is the 50% water level. **All water levels are measured from the *true volume* of the bottle, not what the bottle is marked as on the shelf!**

The following chart lists water markings for typical bottles. All measurements are in centimeters, and are measured from the bottom ring of the mid-section of the bottle.

Bottle Type	Volume	30%	40%	50%	60%	70%
1-Liter Poland Springs	1.10 L	2.5	4.0	5.5	7.0	8.5
2-Liter Coca-Cola	2.19 L	3.0	5.0	7.0	9.0	11.0

Appendix B

Stability Markings

Just as we can mark water levels on our rocket, we can also mark the stability. Stability markings are helpful on a rocket, because they allow you to change parachutes or other mass inside, without having to do the math or using a computer simulator to recalculate the stability. Here's a typical marking system:

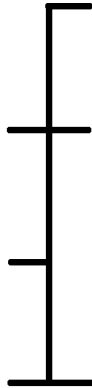

Figure B.1: Typical Stability Markings

The bottom line indicates the center of pressure of the rocket. The lines above it mark the center of gravity locations for 0.5, 1.0, and 1.5 calibers of stability. Remember, the distance between the center of pressure and center of gravity of a rocket with 1.0 caliber of stability is equal to the diameter of the rocket body.

With stability markings, testing your rocket for stability is simple. Pack your parachutes and any other parts of the rocket as if they were ready to fly. Then, try to balance the rocket body on the side of your finger. The point at which the rocket balances is the center of gravity. Use the stability markings to determine your rocket's stability.

Appendix C

Rocket Material Weights

In chapter 5, we looked at how to calculate a rocket's stability by using the plans, without actually building the rocket. To do this, you must first know the weight of the materials you are going to use, so you can accurately estimate the rocket's center of gravity. The values on the following pages contain weights of some common materials.

C.1 Bottles

The following table lists the mass of some 1 and 2 liter bottles. These values should be used for estimating the mass of the pressurized bottle of the rocket:

Volume	Brand	Mass
1 L	Poland Springs	37.8 g
2 L	Coca-Cola	48.6 g
2 L	Publix	50.2 g
2 L	Sam's Choice	51.1 g

For other parts of the rocket, which are made from pieces of plastic bottles, but not necessarily the whole value, we must look at the weight of each particular section of the bottle. For strength reasons, the plastic of the bottle varies in thickness. Typically, the neck and the base have the thickest plastic, while the flat, middle section is made of thinner plastic.

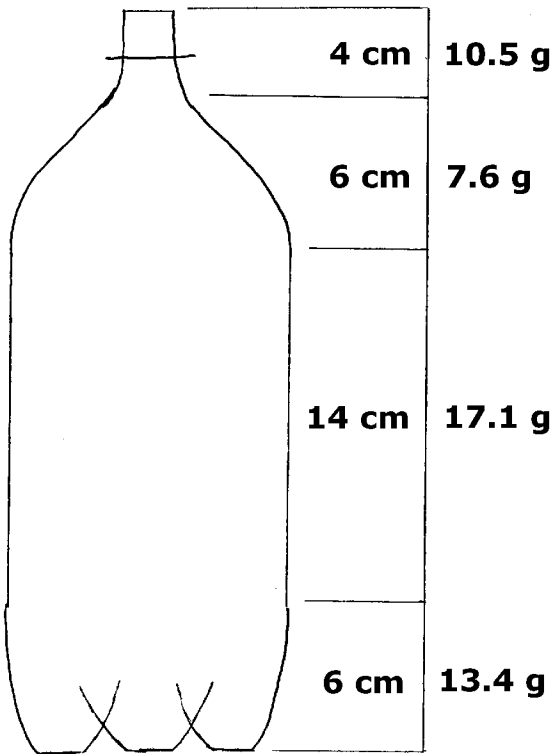

Figure C.1: Weight breakdown of 2 liter Coca-Cola bottle. (Total weight: 48.6 g)

If you are using the flat, mid-section from a bottle as part of your rocket, you can estimate the weight of it by using the following values:

Volume	Brand	Mass by Surface Area	Mass of Ring
1 L	Poland Springs	460 g/m ²	1.2 g/cm
2 L	Coca-Cola	350 g/m ²	1.2 g/cm

You can either use the values in the third or fourth columns, depending on how you measure your piece. If you know the surface area of your piece, convert the value to square meters, and multiply by the value in the third column. If you are cutting

a ring from the mid-section of a bottle, simply take the height, in cm, and multiply by the value in the fourth column.

C.2 Balsa Wood

Balsa wood varies in weight, so to get an accurate value, you must weigh the wood before you use it. The following chart lists common ranges of the weight of balsa wood:

Thickness	Mass
1/32"	50 – 150 g/m ²
1/16"	150 – 300 g/m ²
3/32"	300 – 600 g/m ²

C.3 Tape

Always use a light tape such as packaging tape when attaching rocket parts. Other tapes may be stronger, but are not necessary, and add excess weight to the rocket.

Tape	Mass by Surface Area	Mass by Length (2" Width)
Packaging Tape	60 g/m ²	3 g/m
Duct Tape	200 g/m ²	10 g/m
Aluminum Tape	300 g/m ²	15 g/m

C.4 String

Some type of string is needed for parachute shroud lines. Look for shroud lines that are light, but also very strong, as you can see in the chart below. Dacron weighs only slightly more than regular cotton string, but it is much stronger.

String	Strength	Mass
Cotton	5 lbs.	0.16 g/m
Dacron	30 lbs.	0.18 g/m

C.5 Other Materials

Here are some typical values for other materials that you may use while building your rocket:

Material	Mass
Cardboard	500 – 800 g/m ²
Dry Cleaning Bags	15 – 25 g/m ²

Appendix D

Parachute Materials Chart

This chart lists approximate thickness and density values for common parachute materials. The formulas for calculating a parachute's size and mass using these values were shown in the chapter *Elliptical Parachute Algorithms*.

Material	Thickness (cm)	Density (g/cm^3)
Plastic (Small Dry Cleaning Bag)	0.0021	0.730
Plastic (Large Dry Cleaning Bag)	0.0031	0.730
Tyvek (Priority Mail Envelope)	0.0188	0.342

Appendix E

Further Reading

The following Internet sites are filled with great information on water rocketry:

Baals Wind Tunnel

<http://ldaps.ivv.nasa.gov/Curriculum/tunnel.html>

A simple wind tunnel that can be built for under \$200.

Clifford Heath's Water Rockets Page

<http://www.osa.com.au/~cjh/rockets/>

A simple water rocket simulator, plus lots of great water rocket links.

Dave Johnson's Water Rocket Annex

<http://www.geocities.com/CapeCanaveral/Lab/5403/>

Originator of the Airspeed Flap.

Paul Grosse's Water Rocket Index

<http://ourworld.compuserve.com/homepages/pagrosse/h2oRocketIndex.htm>

A large site containing various information on water rockets.

VCP CP/CG Stability Calculator

<http://www.impulsaero.com/Software/VCP/index.html>

The best program for calculating stability using the Barrowman Equations.

Water Rocket Equations by Den TAP

<http://www.fortunecity.com/tattooine/cluster/145/rocket/theory/contents.htm>

A great site, containing many of the equations mentioned in the *Simulators* chapter.